

Tebis Application software

TL208A V 1.x Lighting and Shutters
Lighting functions

	Product reference	Product designation
	TXA 208A TXA 208B TXA 208C TXA 208D	Output module 8-fold 4A 230V~ with local command separated from bus Output module 8-fold 10A 230V~ with local command separated from bus Output module 8-fold 16A 230V~ with local command separated from bus Output module 8-fold 16A 230V~ capacitive load with local command separated from bus

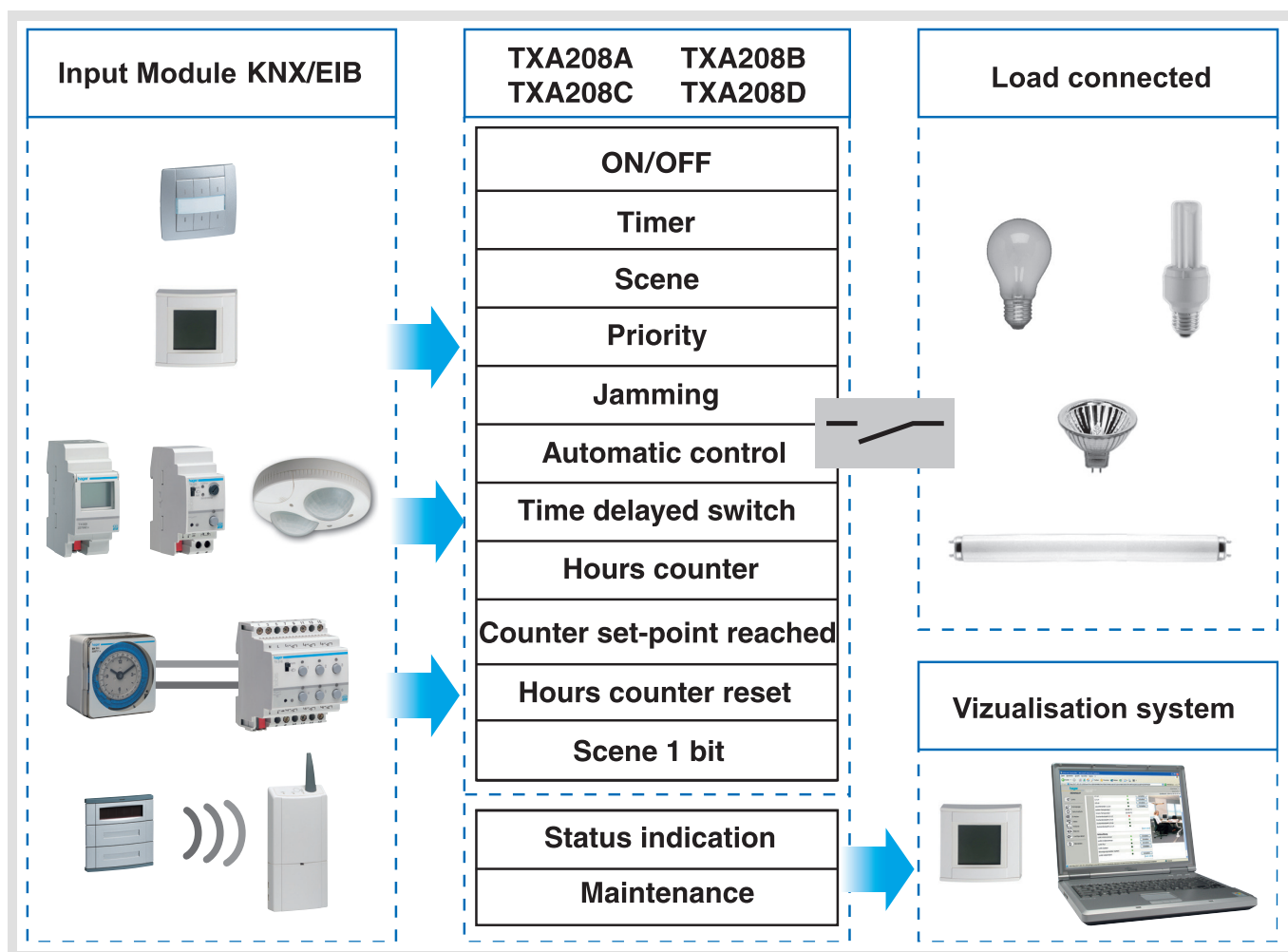

Summary

1. Presentation of the Lighting functions of the TL208A application	2
2. Configuration and parameters of the Lighting functions	3
2.1 General parameters.....	3
2.2 Objects list.....	4
2.3 Functions description.....	4
3. Main characteristics	15
4. Physical addressing	16

1. Presentation of the Lighting functions of the TL208A application

The TL208A application software allows each output to be individually configured for Lighting or Shutters/Blinds applications. The main functions of the Lighting application are the following :

■ ON/OFF

The ON/OFF function allows ON or OFF switching of a lighting circuit.
The command may come from switches, pushbuttons or automatic controls.

■ Status indication

The Status indication function displays the status of the output contact.
It allows a toggle function to be created by sending the status indication to each pushbutton of the group.

■ Timer

The Timer function allows ON or OFF switching of a lighting circuit for an adjustable time.
Depending on the timer operation selected, the output may be delayed for ON or OFF. The timer can be interrupted before the end of the delay time. An adjustable cut-OFF pre-warning indicates the end of the delay time by inverting the status of the output for 1 sec.

■ Time limited toggle switch

The Time delayed switch function combines a toggle function and a cut-off delay.
Pressing briefly a pushbutton inverts the output. If the output is ON, it switches automatically to OFF after a programmable delay time (energy savings).
Application : lighting of attics, cellars, sheds, etc.

■ Priority

The Priority function allows overriding an output to a definite status, ON or OFF.
This command has the highest priority. No other command is taken into consideration if a priority is active. Only a priority end command enables again the other commands.
Application : maintaining a lighting on for safety reasons.

■ Jamming

The Jamming function allows locking an output in its current status.
This command has priority, but at a lower level than the Priority function. Jamming forbids any action until a jamming end command is sent.
The jamming duration can be delayed.

■ Scene

The Scene function allows grouping a set of outputs. These outputs can be put in a parameterisable predefined status.
Pressing one single pushbutton activates a scene.
Each output may be integrated in 32 different scenes.

■ Timer and automatic controls

The Timer and automatic controls function allow the outputs to be controlled by :

- Timer functions : Timer/toggle change over, Timer, Switching delay, Tripping delay, Switching and tripping delay,
- Automatic control functions : Authorization, logical AND or OR combinations.

■ Hours counter

The Hours counter function allows counting the ON or OFF time of an output.
A set-point triggering an alarm may be programmed. The counting value can be reset to zero.

■ Manual mode

The Manual mode isolates the product from the bus.
In this mode, it is possible to override manually each output.

2. Configuration and parameters of the Lighting functions

2.1 General parameters

■ ETS version selection

This parameter allows the presentation of the parameters to be optimised according to the ETS version used. Go to the ETS Version screen and select the required version : ETS2 or ETS3.

Default value : ETS3.

■ Select function

Go to the General screen and select Lighting for the outputs concerned.

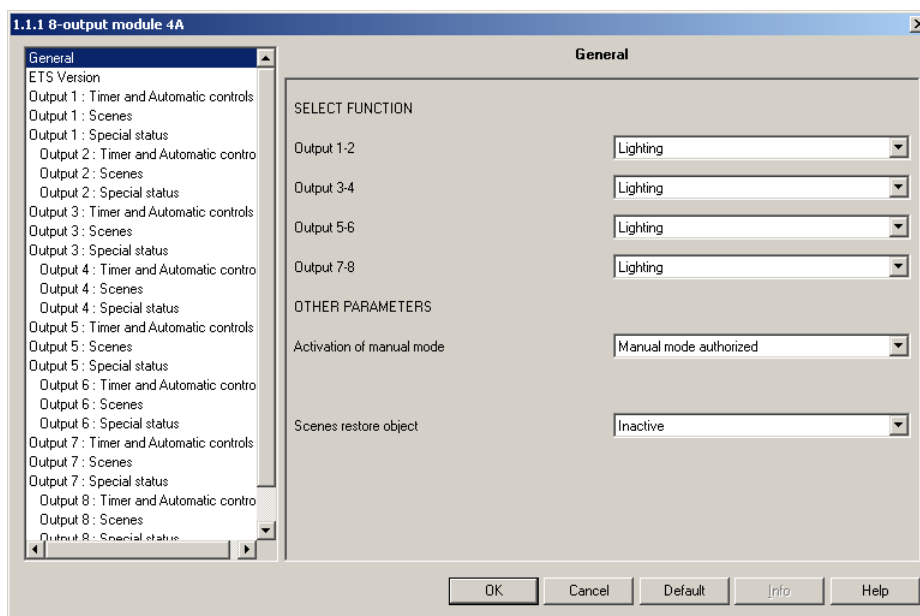

Screen 1

■ Other parameters

Designation	Description	Values
Activation of the Manual mode*	This parameter enables or disables the 2 position switch located on the front side of the product. This switch allows selecting the Manual mode or the Auto mode. In Manual mode, the outputs may be controlled using the pushbuttons on the front side of the product. In Auto mode, the outputs are controlled by the instructions coming from the bus.	Manual mode authorized, Manual mode inhibited, Manual mode time limited. - Manual mode authorized : the manual mode can be activated at any time. - Manual mode inhibited : the switch is permanently disabled. Switching to manual mode is impossible. - Manual mode time limited : the manual mode can be activated for a limited duration. Default value : Manual mode authorized.
Duration of manual mode activation**	This parameters defines the duration of activation of the manual mode.	15, 30, 60 min. Default value : 15 min.
Scenes restore object (see also Scene function)	If the value is Active, the values linked with the scenes at the last download are restored when receiving this object.	Inactive, Active. Default value : Inactive.

* When the position of the switch is not in line with the status of the product, the indicators associated with the outputs light up sequentially.

** This parameter only is visible if the Manual mode activation parameter has the value Manual mode time limited.

2.2 Objects list

Number	Name	Object Function	Length	C	R	W	T	U	Priority	Number	Name	Object Function	Length	C	R	W	T	U	Priority	
0	Output 1	ON/OFF	1 bit	C	R	W	-	U	Low	34	Output 7	Status indication	1 bit	C	R	-	T	U	Low	
1	Output 1	Timer	1 bit	C	R	W	-	U	Low	35	Output 8	ON/OFF	1 bit	C	R	W	-	U	Low	
2	Output 1	Priority	2 bit	C	R	W	-	U	Low	36	Output 8	Timer	1 bit	C	R	W	-	U	Low	
3	Output 1	Scene	1 Byte	C	R	W	-	U	Low	37	Output 8	Priority	2 bit	C	R	W	-	U	Low	
4	Output 1	Status indication	1 bit	C	R	-	T	U	Low	38	Output 8	Scene	1 Byte	C	R	W	-	U	Low	
5	Output 2	ON/OFF	1 bit	C	R	W	-	U	Low	39	Output 8	Status indication	1 bit	C	R	-	T	U	Low	
6	Output 2	Timer	1 bit	C	R	W	-	U	Low	42	Output 1	Jamming	1 bit	C	R	W	-	U	Low	
7	Output 2	Priority	2 bit	C	R	W	-	U	Low	47	Output 1	Time limited toggle switch	1 bit	C	R	W	-	U	Low	
8	Output 2	Scene	1 Byte	C	R	W	-	U	Low	49	Output 2	Jamming	1 bit	C	R	W	-	U	Low	
9	Output 2	Status indication	1 bit	C	R	-	T	U	Low	54	Output 2	Time limited toggle switch	1 bit	C	R	W	-	U	Low	
10	Output 3	ON/OFF	1 bit	C	R	W	-	U	Low	56	Output 3	Jamming	1 bit	C	R	W	-	U	Low	
11	Output 3	Timer	1 bit	C	R	W	-	U	Low	61	Output 3	Time limited toggle switch	1 bit	C	R	W	-	U	Low	
12	Output 3	Priority	2 bit	C	R	W	-	U	Low	63	Output 4	Jamming	1 bit	C	R	W	-	U	Low	
13	Output 3	Scene	1 Byte	C	R	W	-	U	Low	68	Output 4	Time limited toggle switch	1 bit	C	R	W	-	U	Low	
14	Output 3	Status indication	1 bit	C	R	-	T	U	Low	70	Output 5	Jamming	1 bit	C	R	W	-	U	Low	
15	Output 4	ON/OFF	1 bit	C	R	W	-	U	Low	75	Output 5	Time limited toggle switch	1 bit	C	R	W	-	U	Low	
16	Output 4	Timer	1 bit	C	R	W	-	U	Low	77	Output 6	Jamming	1 bit	C	R	W	-	U	Low	
17	Output 4	Priority	2 bit	C	R	W	-	U	Low	82	Output 6	Time limited toggle switch	1 bit	C	R	W	-	U	Low	
18	Output 4	Scene	1 Byte	C	R	W	-	U	Low	84	Output 7	Jamming	1 bit	C	R	W	-	U	Low	
19	Output 4	Status indication	1 bit	C	R	-	T	U	Low	89	Output 7	Time limited toggle switch	1 bit	C	R	W	-	U	Low	
20	Output 5	ON/OFF	1 bit	C	R	W	-	U	Low	91	Output 8	Jamming	1 bit	C	R	W	-	U	Low	
21	Output 5	Timer	1 bit	C	R	W	-	U	Low											
22	Output 5	Priority	2 bit	C	R	W	-	U	Low											
23	Output 5	Scene	1 Byte	C	R	W	-	U	Low											
24	Output 5	Status indication	1 bit	C	R	-	T	U	Low											
25	Output 6	ON/OFF	1 bit	C	R	W	-	U	Low											
26	Output 6	Timer	1 bit	C	R	W	-	U	Low											
27	Output 6	Priority	2 bit	C	R	W	-	U	Low											
28	Output 6	Scene	1 Byte	C	R	W	-	U	Low											
29	Output 6	Status indication	1 bit	C	R	-	T	U	Low											
30	Output 7	ON/OFF	1 bit	C	R	W	-	U	Low											
31	Output 7	Timer	1 bit	C	R	W	-	U	Low											
32	Output 7	Priority	2 bit	C	R	W	-	U	Low											
33	Output 7	Scene	1 Byte	C	R	W	-	U	Low											

2.3 Functions description

■ ON/OFF function and status indication

The ON/OFF function allows the output to be switched ON or OFF using the ON/OFF object. The status of the output depends on the activation of other functions and of the associated parameters : priority, output type, automatic control, scene, etc. The status of the output is indicated on the bus by the Status indication object.

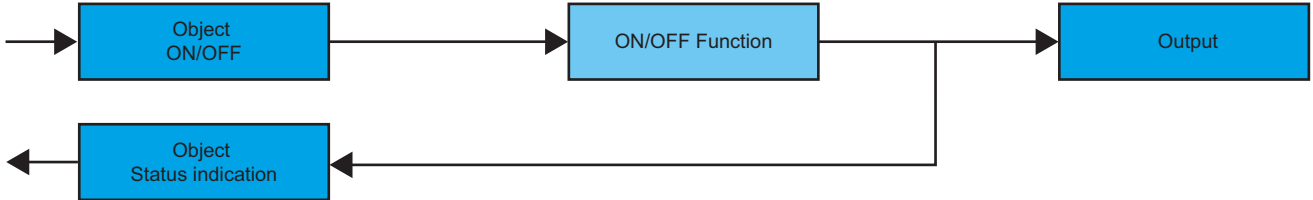

■ Timer function

The Timer function allows ON or OFF switching of a lighting circuit for an adjustable time. The function is started by the Timer object.

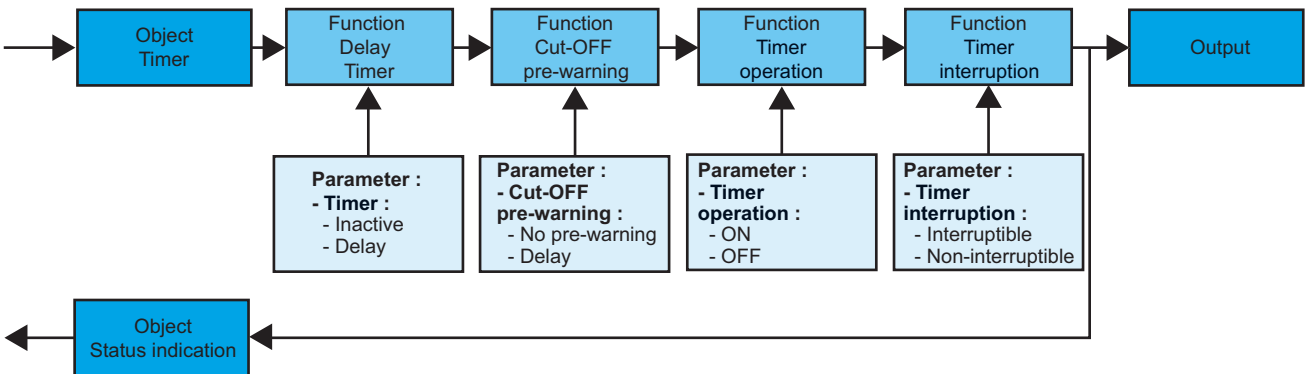

→ Parameters

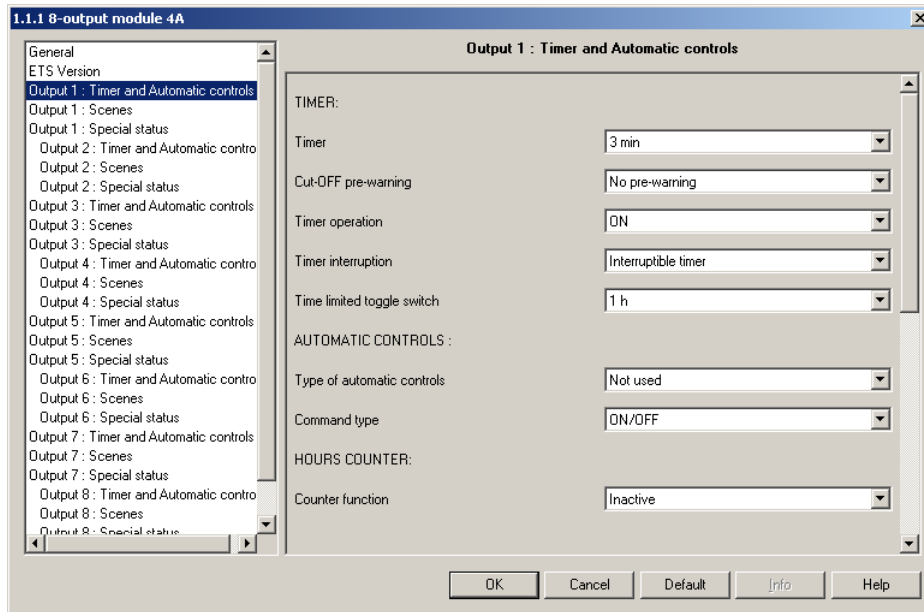

Screen 2

Designation	Description	Values
Timer	This parameter defines the length of the time delay.	Inactive, Range [0.5 s 24 h]* Default value : 3 min.
Cut-OFF pre-warning (in ON operation)	When the pre-warning is active, the output switches to OFF for 1 sec. The value of the parameter defines the time before the end of the delay time, when the pre-warning will be applied.	No pre-warning, 15 s, 30 s, 1 min. Default value : No pre-warning.
Timer operation	This parameter defines whether the delay time triggers an ON or an OFF status.	ON, OFF Default value : ON.
Timer interruption	This parameter allows or not the interruption of the timer when the associated pushbutton is pressed for a long time.	Interruptible timer, Non-interruptible timer, Default value : Interruptible timer.

* Setting range [0.5 s 24 h]

0.5 s, 1 s, 2 s, 3 s, 5 s, 10 s, 15 s, 20 s, 30 s, 40 s, 45 s, 50 s, 1 min, 1 min 15 s, 1 min 30 s, 2 min, 2 min 30 s, 3 min, 4 min, 5 min, 6 min, 7 min, 8 min, 9 min, 10 min, 11 min, 12 min, 13 min, 14 min, 15 min, 20 min, 30 min, 40 min, 50 min, 1 h, 1 h 30 min, 2 h, 2 h 30 min, 3 h, 3 h 30 min, 4 h, 5 h, 6 h, 12 h, 24 h.

Note :

- Timer commands repeated n times during the first ten seconds after the beginning of the delay time multiply the duration of the delay time by n times the value of the Timer parameter
- A command given 10 sec after the beginning of the delay time restarts the timer only once

■ Time limited toggle switch function

The Time limited toggle switch function allows a toggle with a settable switch-off delay time to be created (energy savings). This function is started by the Time limited toggle switch object.

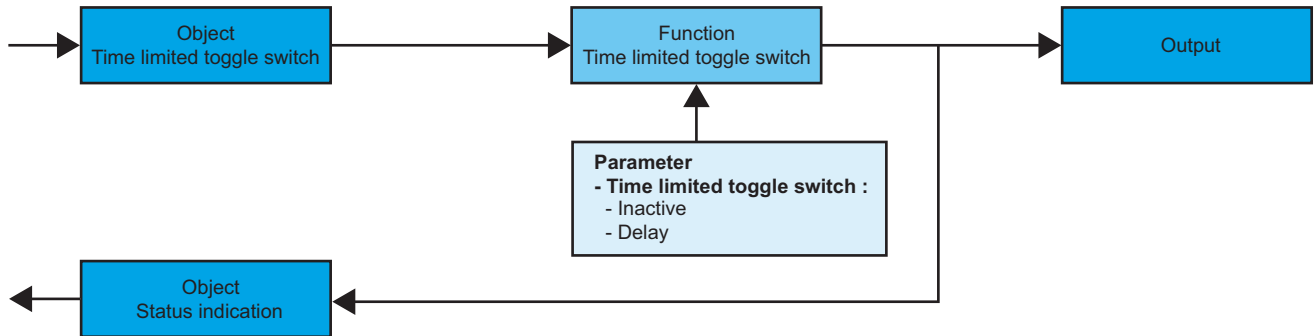

→ Parameters setting screen : see "Screen 2".

→ Parameter

Designation	Description	Values
Time limited toggle switch	This parameter defines the duration of the switch-off delay time.	Inactive, Range [0.5 s 24 h]* Default value : 1 h.

* Setting range [0.5 s 24 h]

0.5 s, 1 s, 2 s, 3 s, 5 s, 10 s, 15 s, 20 s, 30 s, 40 s, 45 s, 50 s, 1 min, 1 min 15 s, 1 min 30 s, 2 min, 2 min 30 s, 3 min, 4 min, 5 min, 6 min, 7 min, 8 min, 9 min, 10 min, 11 min, 12 min, 13 min, 14 min, 15 min, 20 min, 30 min, 40 min, 50 min, 1 h, 1 h 30 min, 2 h, 2 h 30 min, 3 h, 3 h 30 min, 4 h, 5 h, 6 h, 12 h, 24 h.

■ Priority function

The Priority function allows the outputs to be forced and maintained at a definite ON or OFF status imposed by the input. This function is started by the Priority object (EIS priority). Priority is the function with the highest priority. Only a priority end command ends the Priority and allows again the commands from the bus to be taken into consideration.

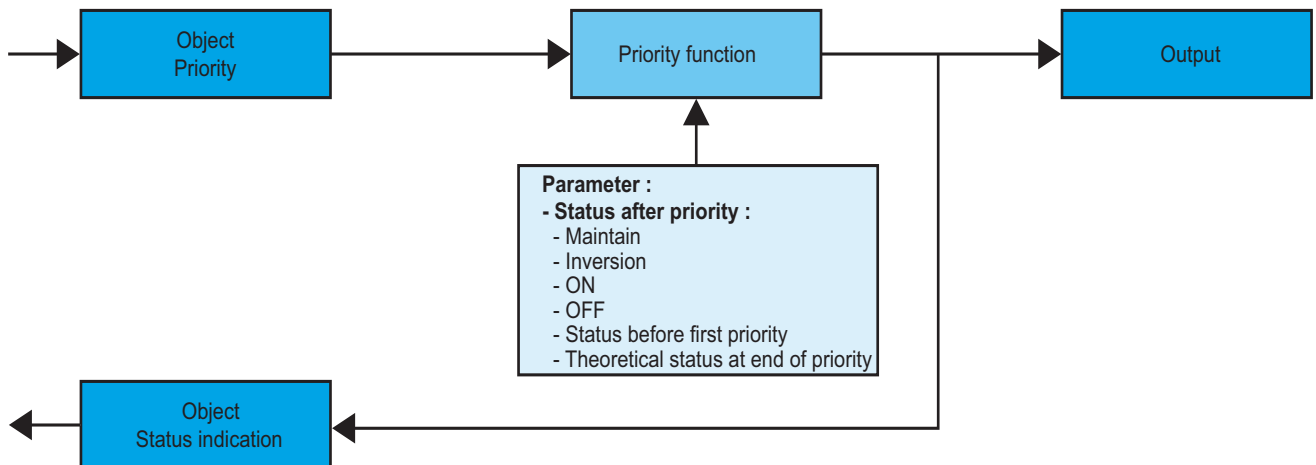

→ Priority function description (EIS priority).

Bit 1	Bit 0
Output behaviour	

Output behaviour	00 or 01 = Priority end 10 = OFF priority 11 = ON priority
------------------	--

→ Parameter

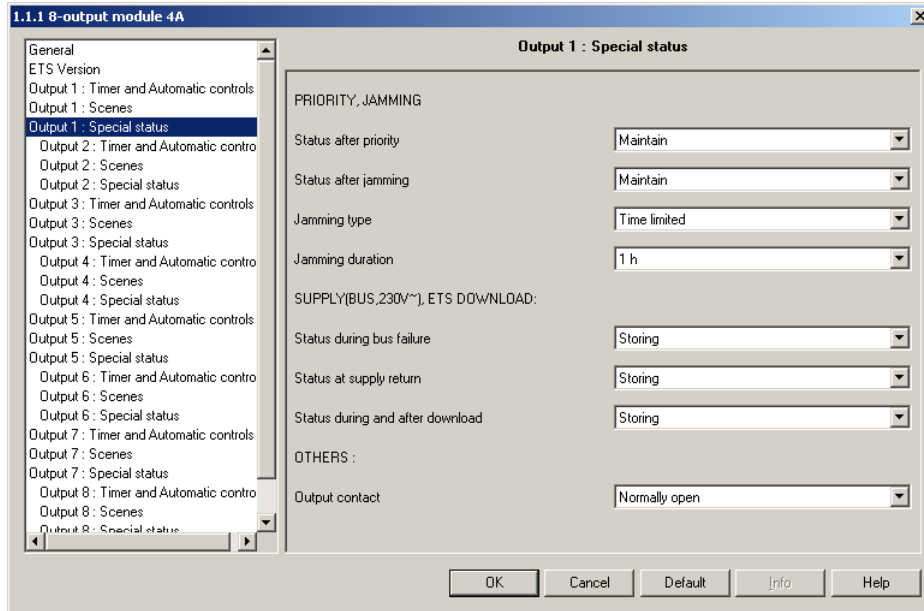

Screen 3

Designation	Description	Values
Status after priority	This parameter defines the output status to be applied at the end of the Priority.	Maintain, Inversion, ON, OFF, Status before first priority, Theoretical status at end of priority. Maintain : maintains the output at the status active during Priority. Inversion : inversion of the output status with regards to the status active during Priority (ON to OFF and OFF to ON). ON : switches the output to ON. OFF : switches the output to OFF. Status before first priority : switches the output to the status active before the Priority command. Theoretical status at end of priority : switches the output to the status that would be active if no Priority command had occurred. Default value : Maintain.

■ Jamming function

The Jamming function allows the outputs to be locked in their current status.

This function is started by the Jamming object. The Jamming function is the function with the second highest priority after Priority. A Jamming end command ends the jamming and allows again taking the commands from the bus into consideration. A Priority command ends the Jamming.

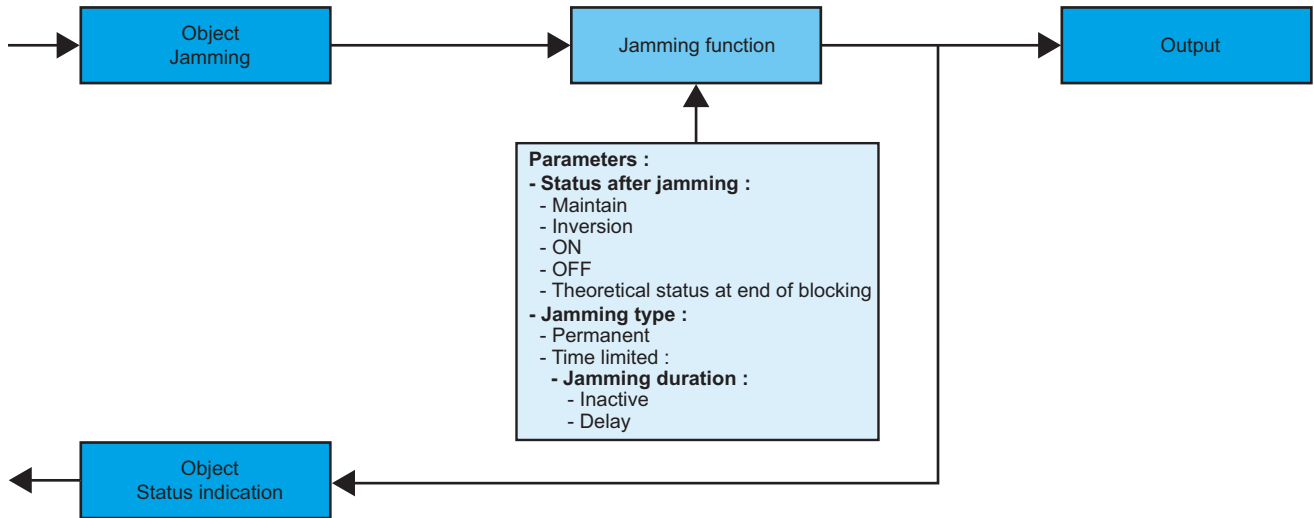

→ Parameters setting screen : see "Screen 3".

→ Parameters

Designation	Description	Values
Status after jamming	This parameter defines the output status to be applied at the end of the Jamming.	Maintain, Inversion, ON, OFF, Theoretical status at end of blocking. Maintain : maintains the output at the status active during Jamming. Inversion : inversion of the output status with regards to the status active during Jamming (ON to OFF and OFF to ON). ON : switches the output to ON. OFF : switches the output to OFF. Theoretical status at end of blocking : switches the output to the status that would be active if no Jamming command had occurred. Default value : Maintain.
Jamming type	This parameter defines whether Jamming is permanent or time-limited.	Permanent, Time limited. Time limited : Jamming is active for a parameterisable limited duration. Default value : Permanent.
Jamming duration**	This parameter defines the Jamming duration.	Inactive, Range [0.5 s 24 h]* Default value : 1 h.

* Setting range [0.5 s 24 h]

0.5 s, 1 s, 2 s, 3 s, 5 s, 10 s, 15 s, 20 s, 30 s, 40 s, 45 s, 50 s, 1 min, 1 min 15 s, 1 min 30 s, 2 min, 2 min 30 s, 3 min, 4 min, 5 min, 6 min, 7 min, 8 min, 9 min, 10 min, 11 min, 12 min, 13 min, 14 min, 15 min, 20 min, 30 min, 40 min, 50 min, 1 h, 1 h 30 min, 2 h, 2 h 30 min, 3 h, 3 h 30 min, 4 h, 5 h, 6 h, 12 h, 24 h.

** This parameter is only visible when the Jamming type parameter has the value : Time limited.

■ Scene function

A scene allows controlling a group of outputs. Each of the outputs of this group will be put in a status predefined for this scene. The group of outputs is created previously by establishing the link between the outputs that must belong to the scene and the pushbutton that will trigger the scene. Each output may be integrated in 32 different scenes. The status of each output may be defined by parameterising, by learning in the room using the pushbuttons of the installation or on the product.

A. Configuration and storing by means of parameterising

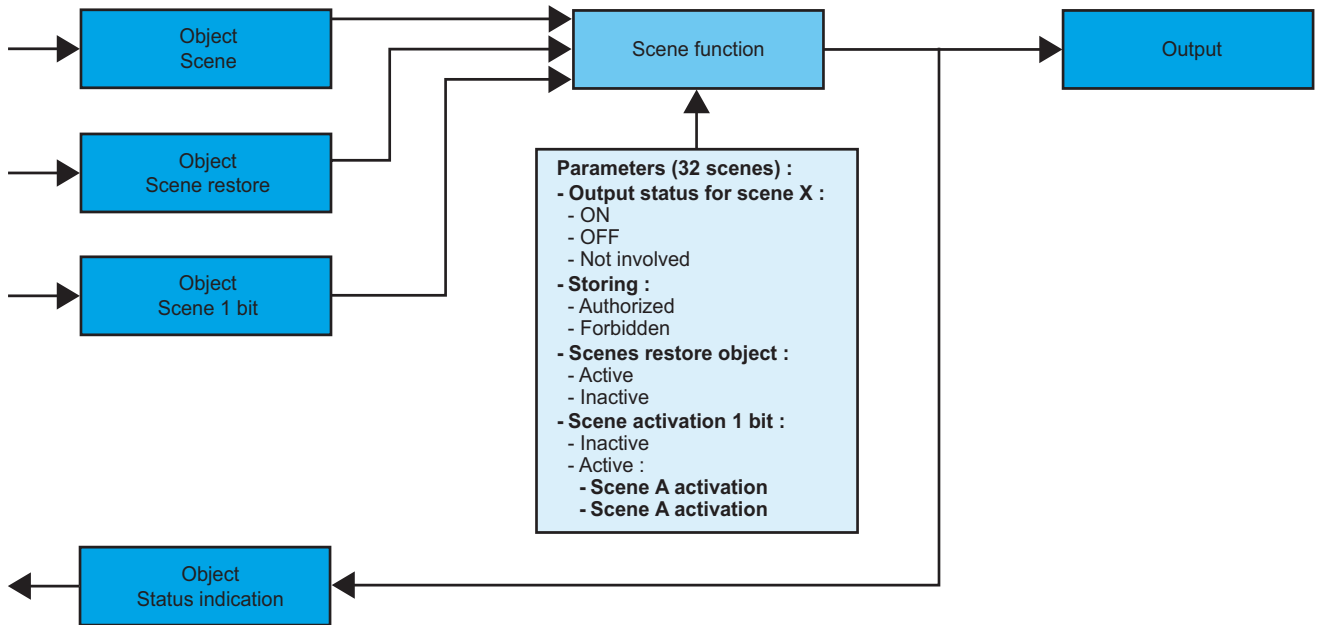

→ Description of scene object (1 byte)

7	6	5	4	3	2	1	0
Learn	X	Scene number					

→ Parameters

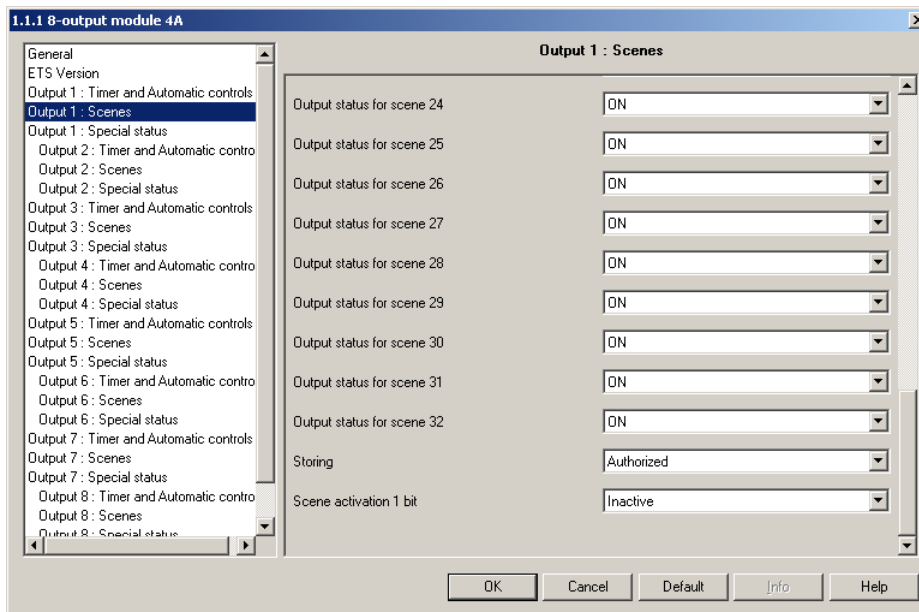

Screen 4

Designation	Description	Values
Output status for scene X	This parameter defines the status of the output linked with scene X.	ON, OFF, Not involved. Note : if the value of the parameter is Not involved, the scene will not influence this output. Default value : ON.
Storing	This parameter authorises or forbids the learning of the scene.	Authorized, Forbidden. Default value : Authorized.
Scene activation 1 bit	This parameter allows 2 scenes among the 32 possible ones to be activated, with the help of the object Scene 1 bit.	Inactive, Active. Default value : Inactive.
Scene A activation / Scene B activation*		No active scene, Scene 1 to scene 32. Default value : No active scene.

* These parameters only are visible if the Scene activation 1 bit parameter has the value : Active.

Note : a Scenes restore object, parameterised in the general screen, allows the values linked with the outputs to be restored at the last download (see paragraph "General parameters").

B. Learning and storing in the room

This procedure allows modifying and storing a scene by means of local action on the pushbuttons located in the room.

- Activate the scene pressing briefly on the room pushbutton that triggers the scene.
- Set the outputs to the desired status using the pushbuttons that control them individually.
- Store the status of the outputs pressing for more than 5 sec the room pushbutton that triggers the scene. The storage is indicated by the status inversion of the involved outputs for 3 sec.

C. Learning and storing on the product

This procedure allows modifying and storing a scene by means of local action on the pushbuttons located on the front side of the products. This procedure also allows an output to be removed from a scene (Not involved).

- Activate the scene pressing briefly on the room pushbutton that triggers the scene.
 - Store the status of the outputs pressing for more than 5 sec the room pushbutton that triggers the scene.
- The switching to the learning mode is indicated by the status inversion of the involved outputs for 3 sec.
- As soon as the indicators associated with the outputs blink slowly, press briefly and repeatedly the pushbuttons linked with the outputs to set the outputs to the desired status. The indicators associated with the outputs show the status chosen :
 - OFF if the value selected for the scene is OFF.
 - Red and continuously ON if the value selected for the scene is ON.
 - Red and quickly blinking if the value selected for the scene is Not involved.
 - Store the status selected for this scene pressing for a time longer than 3 sec the pushbutton associated with the output. The storage is indicated by the return of the slow blinking of the indicators associated with the outputs.
 - Repeat the previous step for each of the outputs of the scene.

■ Timer and Automatic controls functions

The Timer and automatic controls function allow the outputs to be controlled by :

- Timer functions : Timer/toggle change over, Timer, Switching delay, Tripping delay, Switching and tripping delay.
- Automatic control functions : Authorization, logical AND or OR combinations.

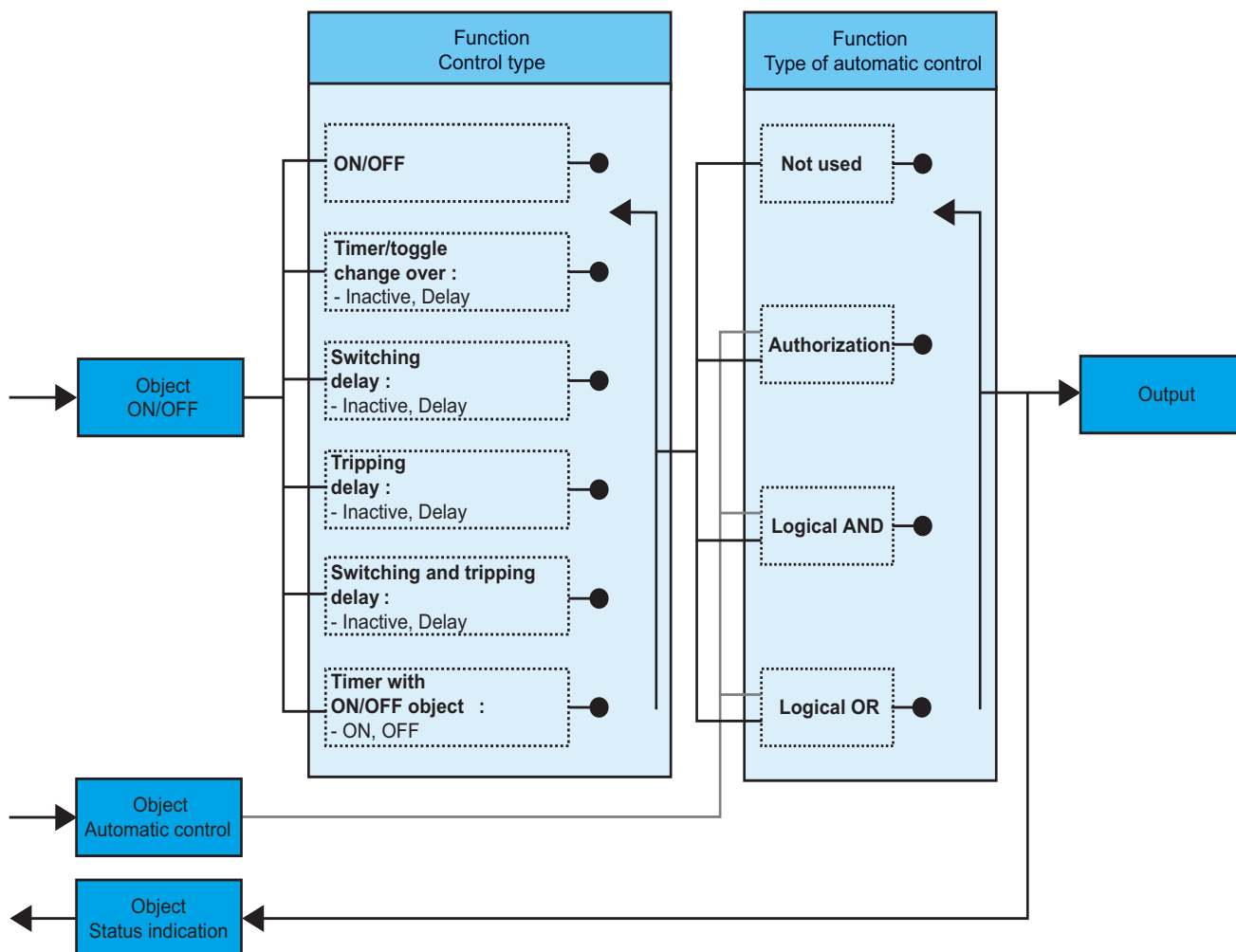

→ Parameters setting screen : see "Screen 2"

→ Parameters

The status of the output depends on the combination of the parameters Type of automatic control and Control type.

Type of automatic control	Control type	Operation	Parameters
Not used (default value)	ON/OFF (default value)	The output is controlled directly. The Automatic control object is ignored.	
	Switching delay	The output is delayed when switching. The Automatic control object is ignored.	Switching delay : Inactive, [0 s 24 h]* Default value : 3 min
	Tripping delay	The output is delayed when tripping. The Automatic control object is ignored.	Switching delay : Inactive, [0 s 24 h]* Default value : 3 min
	Switching and tripping delay	The output is delayed when switching and when tripping. The Automatic control object is ignored. The switching and tripping delay times may be different.	Switching delays : Inactive, [0 s 24 h]* Default value : 3 min
	Timer with ON/OFF object	The output is delayed for ON or for OFF. The Automatic control object is ignored.	Time switch delay : Inactive, [0 s 24 h]* Default value : 3 min Timer operation : ON, OFF Default value : ON
Authorization	Timer/toggle change over	The output is controlled directly by the ON/OFF object if the value of the Automatic control object is 1. The output is delayed for ON or for OFF if the value of the Automatic control object is 0.	Time switch delay : Inactive, [0 s 24 h]* Default value : 3 min Timer operation : ON, OFF Default value : ON
	Switching delay	The output is delayed when switching if the value of the Automatic control object is 1. The commands are not taken into consideration if the value of the Automatic control object is 0.	Switching delay : Inactive, [0 s 24 h]* Default value : 3 min
	Tripping delay	The output is delayed when tripping if the value of the Automatic control object is 1. The commands are not taken into consideration if the value of the Automatic control object is 0.	Switching delay : Inactive, [0 s 24 h]* Default value : 3 min
	Switching and tripping delay	The output is delayed when switching and when tripping if the value of the Automatic control object is 1. The commands are not taken into consideration if the value of the Automatic control object is 0.	Switching delays : Inactive, [0 s 24 h]* Default value : 3 min
	Timer with ON/OFF object	The output is delayed if the value of the Automatic control object is 1. The commands are not taken into consideration if the value of the Automatic control object is 0.	Time switch delay : Inactive, [0 s 24 h]* Default value : 3 min Timer operation : ON, OFF Default value : ON

Type of automatic control	Control type	Operation	Parameters
Logical AND	ON/OFF	The output is the result of the logical AND between the value of the ON/OFF object and the value of the Automatic control object.	
	Switching delay	The output is the result of the logical AND between the value of the ON/OFF object delayed when switching and the value of the Automatic control object.	Switching delay : Inactive, [0 s 24 h]* Default value : 3 min
	Tripping delay	The output is the result of the logical AND between the value of the ON/OFF object delayed when tripping and the value of the Automatic control object.	Switching delay : Inactive, [0 s 24 h]* Default value : 3 min
	Switching and tripping delay	The output is the result of the logical AND between the value of the ON/OFF object delayed when switching and when tripping, and the value of the Automatic control object.	Switching delays : Inactive, [0 s 24 h]* Default value : 3 min
	Timer with ON/OFF object	The output is the result of the logical AND between the value of the delayed ON/OFF object and the value of the Automatic control object.	Time switch delay : Inactive, [0 s 24 h]* Default value : 3 min Timer operation : ON, OFF Default value : ON
Logical OR	ON/OFF	The output is the result of the logical OR between the value of the ON/OFF object and the value of the Automatic control object	
	Switching delay	The output is the result of the logical OR between the value of the ON/OFF object delayed when switching and when tripping, and the value of the Automatic control object.	Switching delay : Inactive, [0 s 24 h]* Default value : 3 min
	Tripping delay	The output is the result of the logical OR between the value of the ON/OFF object delayed when switching and when tripping, and the value of the Automatic control object.	Switching delay : Inactive, [0 s 24 h]* Default value : 3 min
	Switching and tripping delay	The output is the result of the logical OR between the value of the ON/OFF object delayed when switching and when tripping, and the value of the Automatic control object.	Switching delays : Inactive, [0 s 24 h]* Default value : 3 min
	Timer with ON/OFF object	The output is the result of the logical OR between the value of the delayed ON/OFF object and the value of the Automatic control object	Time switch delay : Inactive, [0 s 24 h]* Default value : 3 min Timer operation : ON, OFF Default value : ON

* Setting range [0 s 24 h]

0 s, 1 s, 2 s, 3 s, 5 s, 10 s, 15 s, 20 s, 30 s, 40 s, 45 s, 50 s, 1 min, 1 min 15 s, 1 min 30 s, 2 min, 2 min 30 s, 3 min, 4 min, 5 min, 6 min, 7 min, 8 min, 9 min, 10 min, 11 min, 12 min, 13 min, 14 min, 15 min, 20 min, 30 min, 40 min, 50 min, 1 h, 1 h 30 min, 2 h, 2 h 30 min, 3 h, 3 h 30 min, 4 h, 5 h, 6 h, 12 h, 24 h.

■ Hours counter function

The Hours counter function allows measuring the cumulated ON or OFF time of an output. The value is transmitted by the Hours counter object. A set-point triggering an alarm may be programmed. The alarm is transmitted by the Counter set-point reached object.

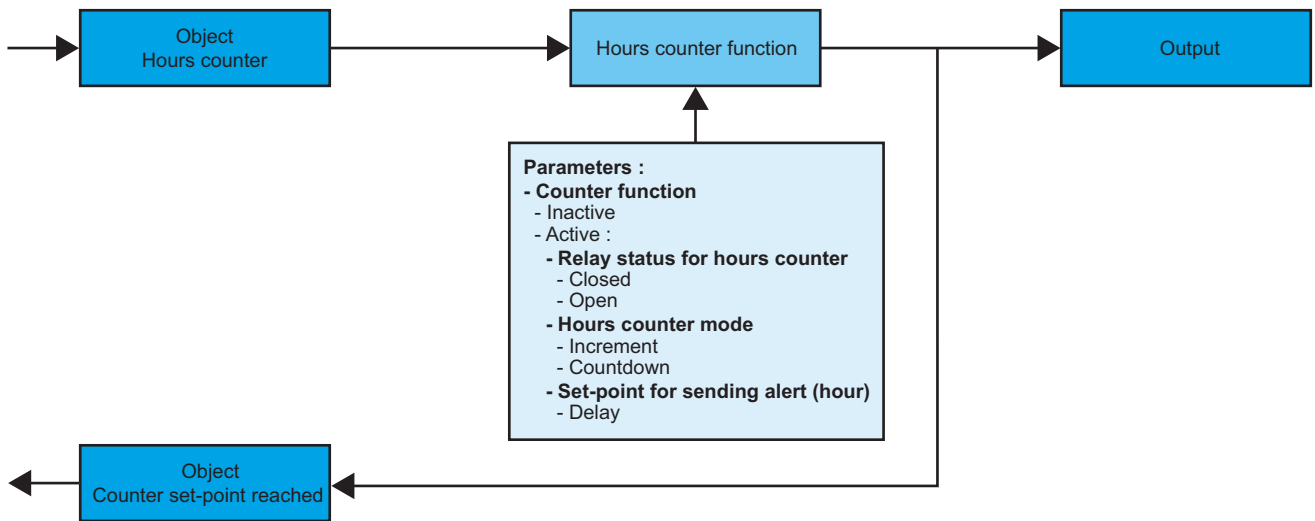

→ Parameters setting screen : see "Screen 2".

→ Parameters

Designation	Description	Values
Counter function	This parameter allows activating the Counter function. The value of the counter can be read through the Hours counter object.	Inactive, Active. Default value : Inactive.
Relay status for hours counter*	This parameter allows choosing the status of which the cumulated time is measured.	Closed, Open. Default value : Closed.
Hours counter mode*	This parameter allows defining the Hours counter mode.	Increment, Countdown. Default value : Increment.
Set-point for sending alert (hour)*	This parameter defines an alarm set-point for which the Counter set-point reached object will be sent.	from 0 to 10000 hours with 1-hour steps. Note : the Counter set-point reached object may be reset either by a new download or by means of a display tool. Default value : 1000.
Periodic sending of hours counter value	This parameter defines the emission periodicity of the Hours counter object.	Not used, [5 s 24 h]*

* Setting range [5 s 24 h]

5 s, 10 s, 30 s, 5 min, 10 min, 20 min, 30 min, 40 min, 50 min, 1 h, 1 h 30 min, 2 h, 2 h 30 min, 3 h, 3 h 30 min, 4 h, 5 h, 6 h, 12 h, 24 h.

■ Special statuses

The parameters grouped in this section allow defining the behaviour of the outputs in some special cases.

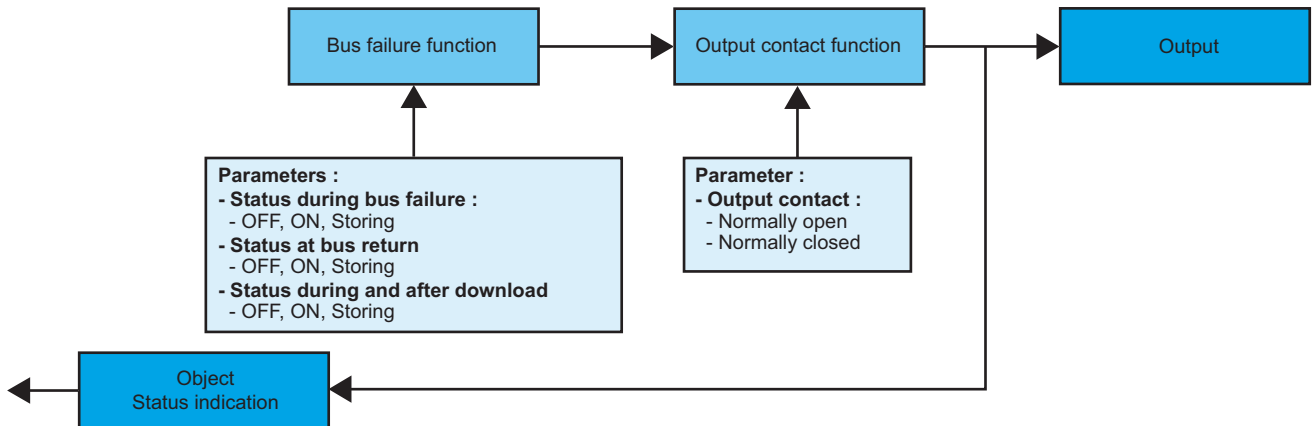

→ Parameters setting screen : see "Screen 3".

→ Parameters

Designation	Description	Values
Status during bus failure	This parameter defines the output status to be applied during Bus failure.	OFF, ON, Storing. Default value : Storing.
Status at bus return	This parameter defines the output status to be applied when the Bus returns.	OFF, ON, Storing. Default value : Storing.
Status during and after download	This parameter defines the output status to be applied during and after download.	OFF, ON, Storing. Default value : Storing.
Output contact	This parameter defines the contact type of the output.	Normally open, Normally closed. Default value : Normally open.

■ Maintenance function

The Maintenance function allows transmitting general data of the product by means of the Maintenance object.

→ Description of maintenance object (2 bytes)

0 0 0 0 0 0 0 0 0 0 0 0 0 0 0 1 C

C : Operating mode of the product	0 : Auto 1 : Manual
-----------------------------------	------------------------

3. Main characteristics

Max. number of group addresses	254
Max. number of links	255
Objects	98 total : 12 per lighting output 1 for scenes restoration 1 for maintenance

4. Physical addressing

To perform physical addressing or check for the presence of the bus, press the lighted pushbutton located above the label holder on the right of the product.

Indicator on = bus present and product in physical addressing.

The product remains in physical addressing until the physical address is transmitted by ETS. Pressing a second time allows leaving the physical addressing mode.

Physical addressing may be performed in Auto or in Manual (↔) mode.

NOTA

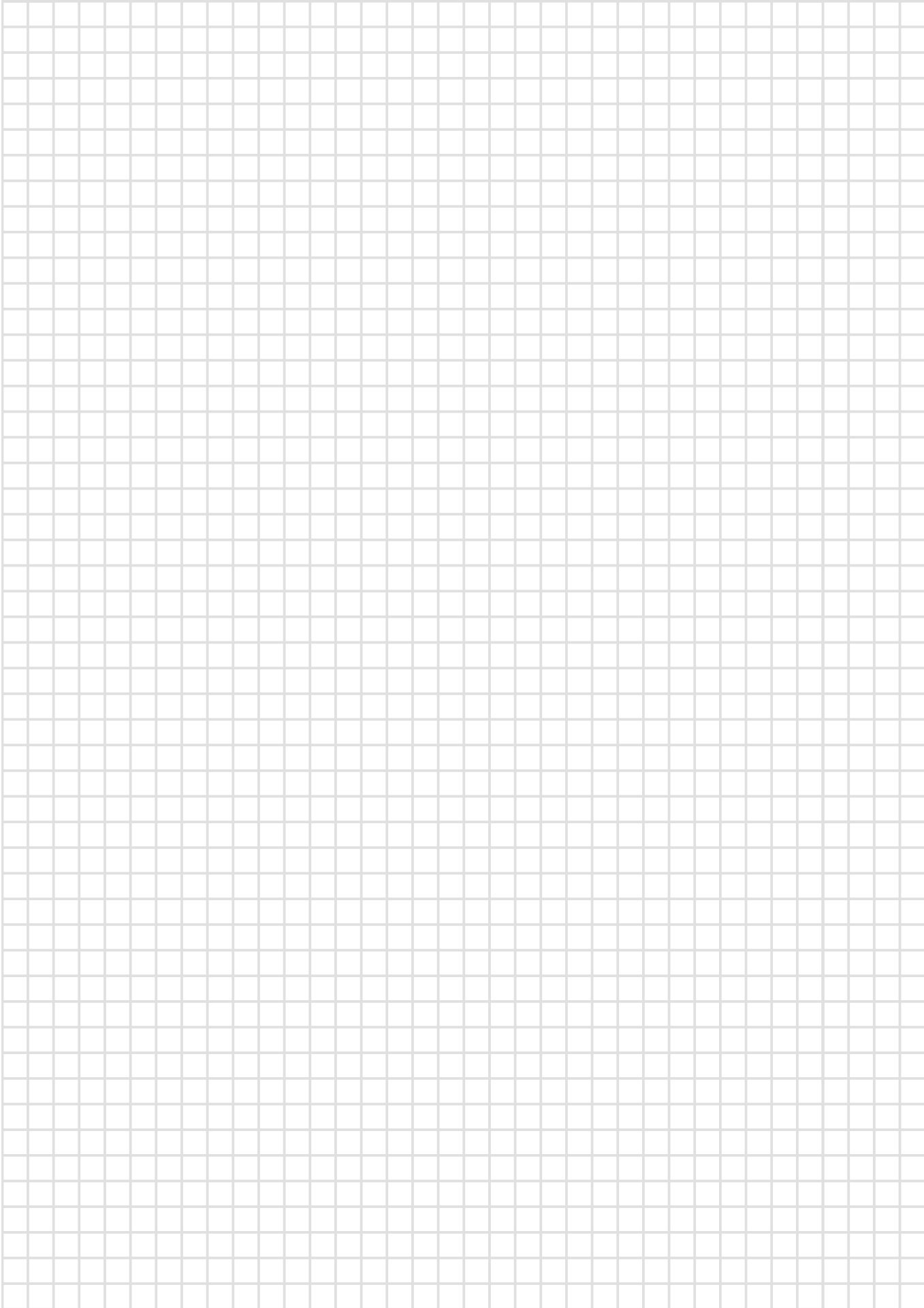

NOTA

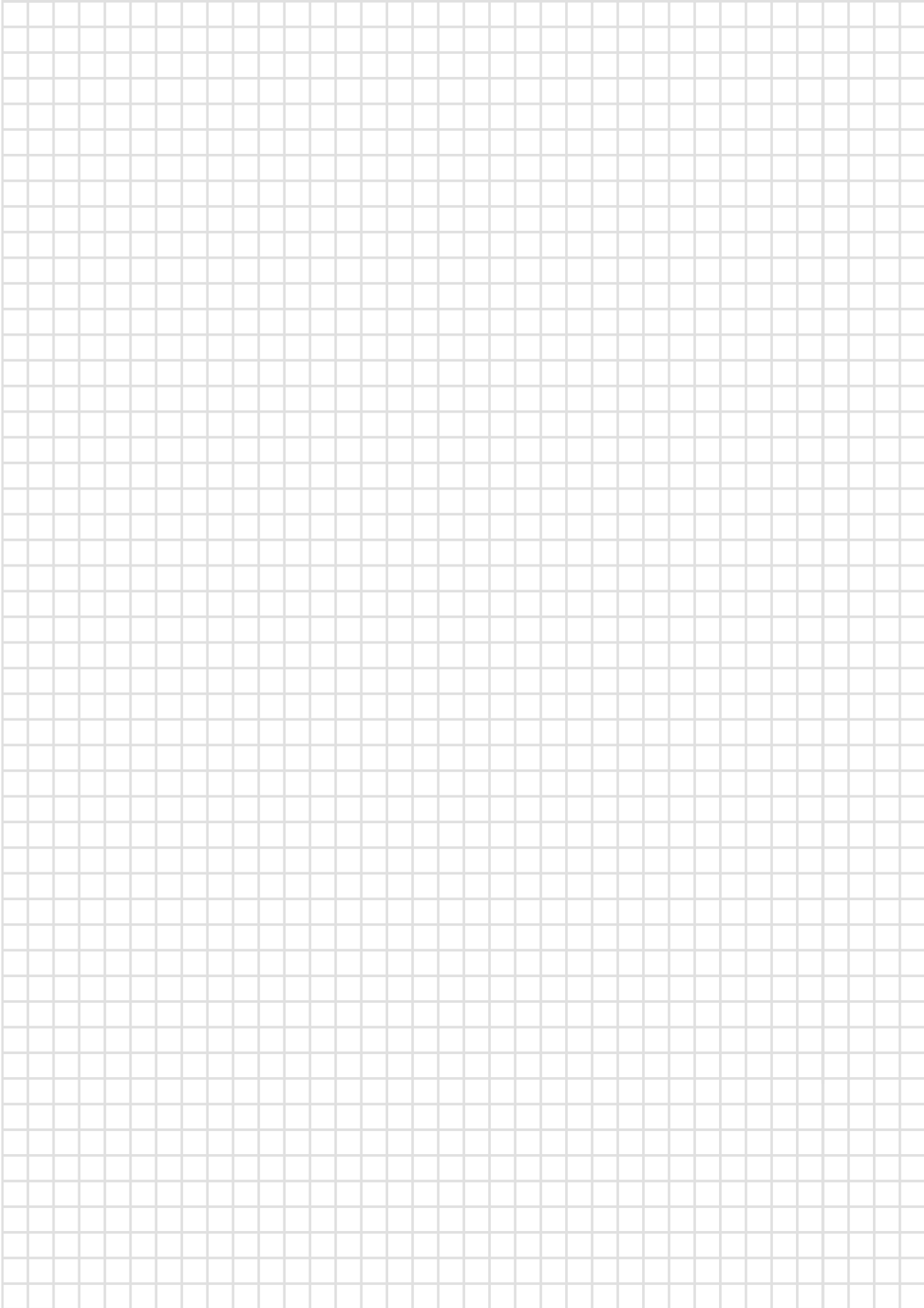

NOTA

