

**Technical characteristics**

	EP 510 EP 515 EP 520	EP 514 EP 516 EP 523	EP 501N EP 503 EP 526	EP 513 EP 518 EP 524	EP 511N EP 519 EP 521	EP 512 EP 517 EP 522	EP 525 EP 540 EP 546	EP 548	EP 528 EP 541 EP 547	EP 529	
<b>Coil in AC</b>											
voltage rating	230V	110V	48V	24V	12V	8V	230V	48V	24V	12V	
tolerance	+10/-20%										
frequency	50/60Hz										
start consumption	25VA						55VA				
<b>Coil in DC</b>											
voltage rating	110V	48V	24V	12V	-	-	110V	24V	12V	-	
tolerance	+10/-20%										
start consumption	12w				-		25w				
<b>Contacts</b>											
max. perm. Current AC1	16A										
voltage	250V AC							400V AC			
electrical endurance	150 000 operations										
mechanical endurance	500 000 operations										
ohmic loss per current path	1.2W										
minimum duration of impulse	50 ms										
maximum time under voltage	1 H										
pushbutton with signal lamp without condensator	6 (1mA / lamp)										
pushbutton with signal lamp with condensator = 1uF parrallel *	10 (1mA / lamp)										
pushbutton with signal lamp with condensator = 2.2uF parrallel *	44 (1mA / lamp)										
ingress protection	IP20										
working temperature	-5 to +40°C										
storage temperature	-40 to 80°C										
<b>Connection</b>											
flexible	6□										
rigid	10□										

\* condensator parrallel with the coil

**Auxiliaries for latching relays**

	EP 050	EP 051	EP 052	EP 053
voltage rating	(a)	-	-	(a)
	24 to 230V AC			
	12to 110V DC		-	-
nominal load	-	2A/250V AC	-	-
Imin/230V AC	-	15mA	-	-
working temperature	-5 to +40°C			
storage temperature	-40 to 80°C			
<b>Connections :</b> flexible	6□			
rigid	10□			

(a) : function of the latching relay connected with an auxiliary

**Latching relay connected with auxiliaries**

	Auxiliaries			
	EP 050	EP 051	EP 052	EP 053
centralised control	x			
centralised control with remote monitoring	x	x		
centralised control with multilevel central control	x		x	
centralised control with remote signalling and multilevel centralised control	x	x	x	
remote signalling		x		
control by maintained contact				x
control by maintained contact with remote signalling		x		x

**Technical characteristics**

The following table shows the number of lamps which can be connected per phase at 230V 50Hz.

**Incandescent lamps  
230V lamps with and  
without halogen**

load :	40W	60W	75W	100W	150W	200W	300W	500W	1000W
number :	45	30	24	15	12	9	5	3	2
<b>Low voltage halogen</b>									
load :	20W	50W	75W	100W	150W	300W			
number :	70	28	19	14	9	3			

**Fluorescent lamps  
uncompensated**

load :	15W	18W	30W	36W	58W				
number :	29	25	25	24	14				

**Parrallel compensation**

load :	15W	18W	30W	36W	58W				
number :	27	27	25	25	16				
C total max <sup>(a)</sup> :	121µF	121µF	112µF	112µF	112µF				

**Two lamp circuit,  
series compensation**

load :	2x18W	2x20W	2x36W	2x40W	2x58W	2x65W			
number :	40	40	22	22	12	12			
C :	2.7µF	2.7µF	3.4µF	3.4µF	5.3µF	5.3µF			
load :	18W	36W	58W						
number :	30	28	15						

**Two lamp circuit with electronics  
power supply units**

load :	2x18W	2x36W	2x58W						
number :	15	13	8						

**Fluo compact uncompensated**

load :	7W	10W	18W	26W					
number :	50	45	40	25					

**Fluo compact electronic power  
supply unit**

load :	11W	15W	20W	23W					
number :	80	60	50	40					

**High intensity discharge  
metal halogen lamps,  
uncompensated**

load :	50W	80W	125W	250W	400W				
number :	11	9	7	3	2				

**Metal halogen lamps,  
parrallel compensation**

load :	50W	80W	125W	250W	400W				
number :	9	8	6	3	2				
C total max <sup>(a)</sup> :	63µF	58µF	60µF	54µF	50µF				

**High pressure sodium vapour  
lamps, uncompensated**

load :	70W	150W	250W	400W					
number :	9	5	3	2					

**High pressure sodium vapour  
lamps, parrallel compensated**

load :	70W	150W	250W	400W					
number :	5	3	2	1					
C total max <sup>(a)</sup> :	60µF	54µF	64µF	50µF					

(a) : these values must not be exceeded

**Installation of the auxiliaries**

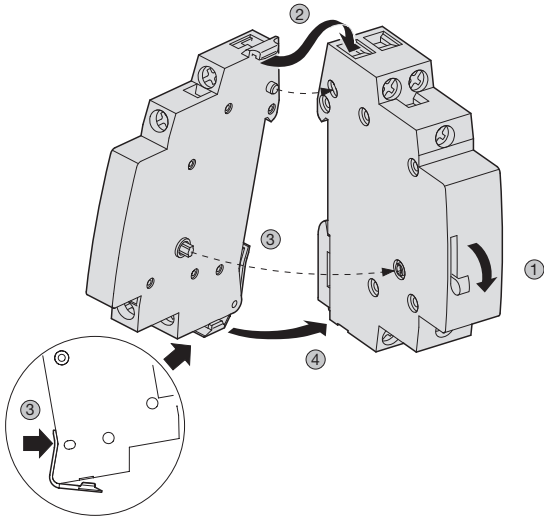

**Application diagram**

**Auxiliaries for centralised control (EP 050 - EP 052)**

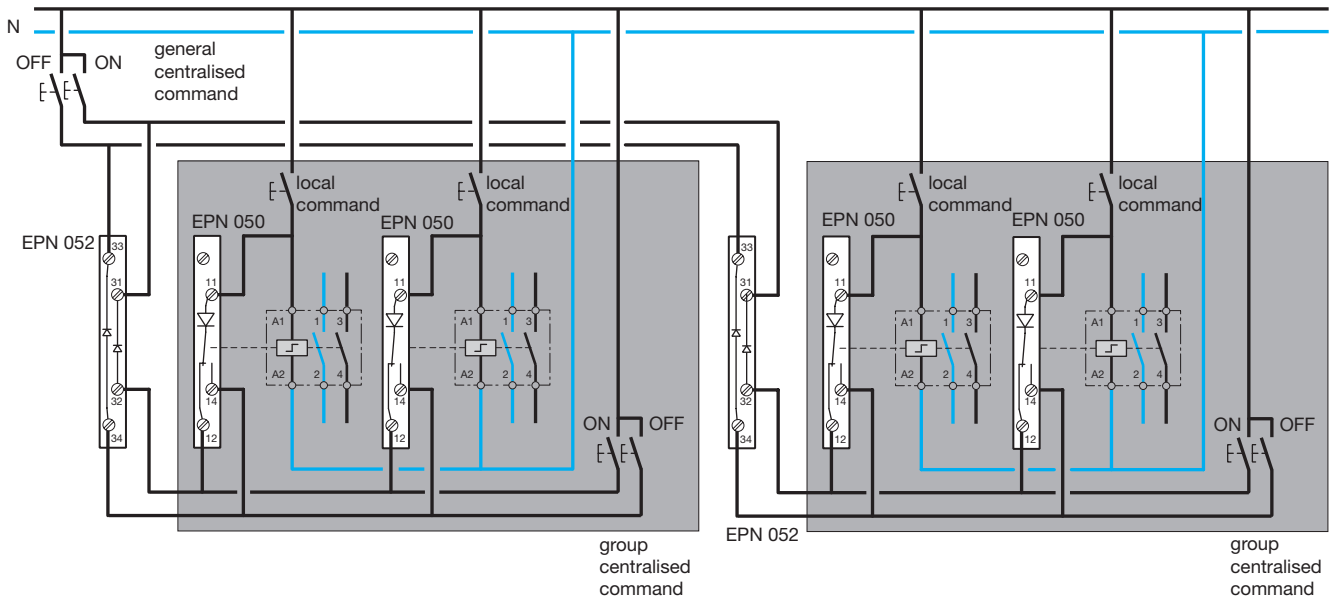

**Auxiliary contact (EP 051)**

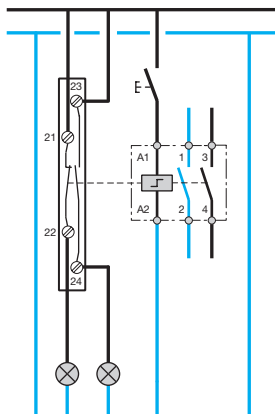

**Auxiliary for control by (EP 053)**

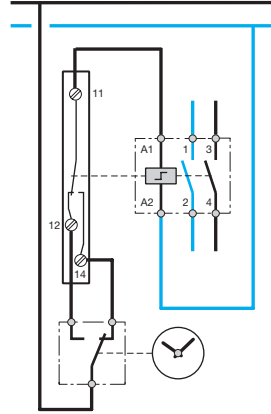

Technical characteristics

		Contactors								Relays			Interface relays	
		ES 110	ES 320	ES 240	ES 263	ES 224	ES 424	ES 252	ES 262	ER 120	ER 123	ER 124	EN 146	EN 145
		ES 210	ES 420	ES 340	ES 365	ES 224A	ES 424A	ES 442	ES 462	ER 135	ER 138	ER 139	(a)	(a)
		ES 220	ES 430	ES 345	ES 463	ES 239	ES 242		ES 492					
		ES 230	ES 320A	ES 440	ES 470									
		ES 237	ES 420A	ES 480	ES 490									
		ES 110A	ES 430A											
		ES 220A	ES 450											
		ES 230A												
Command voltage(V)		230	230	230	230	24	24	24	24	230	24	12	230	10 to 26
Frequency	%	+10/-15 for all products												
	Hz	50/60Hz												
Starting consumption (VA)		15	20	50	50	15	20	50	50	15/20	15/20	15/20	5	(a)
Maintained consumption (VA)		5	5	7	7	5	5	7	7	5	5	5	5	(a)
Max perm. current AC1 (A)		25	25	40	63	25	25	40	63	16	16	16	5	5
Insulation voltage (V)		250	400	400	400	250	250	400	400	250	250	250	250	250
Mech. endur. (%)		1 000 000 for all products												
Working temp. (°C)		-10/+50 for all products												
Storage temp. (°C)		-40/+80 for all products												
Connection														
control	flexible	0.5 to 4□		1 to 2.5□		0.5 to 4□		1 to 2.5□		0.5 to 4□				
	rigid	1 to 6□		1.5 to 4□		1 to 6□		1.5 to 4□		1 to 6□				
power	flexible	1 to 6□				1 to 6□				1 to 6□				
	rigid	1.5 to 10□		4 to 25□		1.5 to 10□		4 to 25□		1.5 to 10□				

Modular devices

Note : (a) electrical endurance : 200 000 operations at 5A AC1

Consumption EN 145

control voltage	start and maintained consumption
12V DC	0.5W
24V DC	1.5W
12V AC	1VA
24V AC	2VA

Auxiliary contacts

auxiliary contacts are available for the range of relays and 25A contactors.

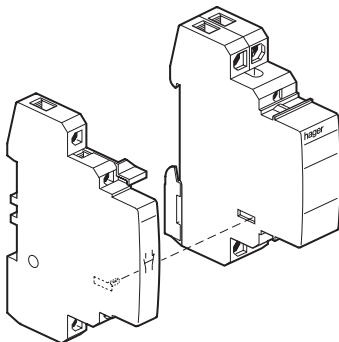

Relays and 25A contactors with manual override

1. permanent ON
2. automatic
3. permanent OFF

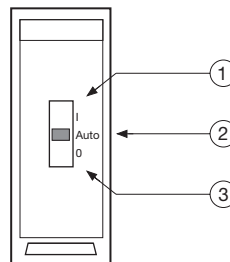

**Choice of contactors :**

The choice of the contactor depends on the type of load (lighting etc.) and on the requirements (number of operations, working temperature).

**Lighting :**

A contactor can control a maximum number of lights as per the table below.

Lamp type		16 A	25 A	40 A	63 A	
<b>Incandescent lamps</b>						
230V lamps with and without halogen	40 W	45	50	100	120	
	60 W	30	35	75	105	
	75 W	24	28	65	90	
	100 W	18	21	45	65	
	150 W	12	14	33	45	
	200 W	9	10	25	35	
	300 W	5	6	16	23	
	500 W	3	4	10	14	
	1000 W	1	2	5	7	
	low voltage halogen	20 W	70	80	160	240
50 W		28	40	80	120	
75 W		19	26	52	78	
100 W		14	20	40	60	
150 W		9	13	26	39	
<b>Fluorescent lamps</b>						
uncompensated	15 W	29	50	110	150	
	18 W	25	42	80	130	
	30 W	25	35	70	110	
	36 W	24	30	60	90	
	58 W	14	20	40	60	
parallel compensation	15 W	25	Cmax. 112	Cmax. 135	Cmax. 202	Cmax. 270
	18 W	25	112	135	202	270
	30 W	20	90	112	180	247
	36 W	20	90	112	180	247
	58 W	15	67	76	99	180
two lamps circuits, series compensation	2 x 18 W 2,7 µF	40	45	90	140	
	2 x 20 W 2,7 µF	40	45	90	140	
	2 x 36 W 3,4 µF	22	26	50	100	
	2 x 40 W 3,4 µF	22	26	50	100	
	2 x 58 W 5,3 µF	12	13	23	50	
	2 x 65 W 5,3 µF	12	13	23	50	
electronics power supply units	18 W	30	35	60	80	
	36 W	26	30	32	45	
	58 W	15	17	25	30	
two lamps circuits with electronics power supply units	2 x 18 W	15	17	30	40	
	2 x 36 W	13	15	16	22	
	2 x 58 W	8	9	12	15	
fluo compact uncompensated	7 W	50	55	100	130	
	10 W	45	50	90	115	
	18 W	40	42	65	90	
	26 W	25	27	50	80	
fluo compact electronic power supply unit	11 W	80	85	110	150	
	15 W	60	63	100	130	
	20 W	50	52	70	110	
	23 W	40	42	60	100	
<b>High intensity discharge</b>						
metal halogen lamps, uncompensated	50 W	11	12	36	50	
	80 W	9	10	27	38	
	125 W	7	8	19	26	
	250 W	3	3	10	14	
	400 W	1	2	7	10	
metal halogen lamps, parrallel compensation	50 W	9	Cmax. 63 µF	Cmax. 70 µF	Cmax. 175 µF	C max. 210 µF
	80 W	7	49 µF	56 µF	147 µF	175 µF
	125 W	5	50 µF	60 µF	140 µF	170 µF
	250 W	3	54 µF	54 µF	126 µF	162 µF
	400 W	1	25 µF	50 µF	100 µF	150 µF
high pressure sodium vapour lamps, uncompensated	70W	9	10	20	30	
	150W	5	6	10	15	
	250W	3	4	6	10	
	400W	1	2	4	6	
high pressure sodium vapour lamps, parrallel compensated	70 W	5	Cmax. 60 µF	Cmax. 72 µF	Cmax. 180 µF	Cmax. 240 µF
	150 W	3	54 µF	54 µF	162 µF	198 µF
	250 W	1	32 µF	64 µF	160 µF	224 µF
	400 W	1	/	50 µF	150 µF	250 µF

### Heating

The choice of the contactor depends on the mechanical resistance (number of operations) and on the electrical heating load i.e. resistive elements, infra-red element, convectors.

### Choice of contactors

The choice of contactor is dependant upon many parameters i.e. operating voltage, size of contacts, number of operations, ambient temperature, type of load supplied etc.

### Type of load

Loads are categorised into various AC ratings, (AC1, AC2, AC3 etc.) and the higher the AC rating the more inductive the load becomes. All Hager contactor ratings are given at AC1, therefore they must be de-rated if used on other types of AC load.

### Heat dissipation inserts

The ambient temperature around a contactor can affect its life expectancy, therefore, we strongly recommend that heat dissipation inserts (LZ 060) are fitted between all contactors and adjacent devices.

**Please consult us, if you require help selecting a suitable contactor.**

### Single phase

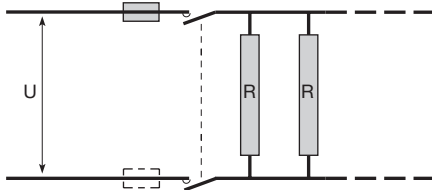

### Three phase

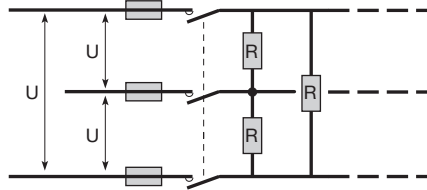

Number of operations	50 000	100 000	150 000	200 000	300 000	single phase 230V	three phase*400V
Maximum load* in kW	4,4	4,4	3,9	3,5	2,9	ES 220 - ES 230	
	7,8	5,9	5	4,4	3,7	ES 240	
	12	8,8	7,7	6,6	5,9	ES 263	
	12	10,5	8,5	6,5	5,8		ES 320 - ES 430
	23,2	17,7	15	13,1	10,8		ES 340
	35	26,3	23	19,7	5,8		ES 463

\* On three phase configuration the maximum load per phase corresponds to the values states divided by 3.

### example:

function of a heating installation 200 days/annum, 100 operations per day (1 opening + 1 closing = 2 operations)  
 mechanical life = 10 years  
 total number of operations: 200 x 100 x 10 = 200,000  
 in that case select an ES 240 to control a load of 4.4 kW (single phase 230V)

### Motors (AC3)

#### Single phase 230V

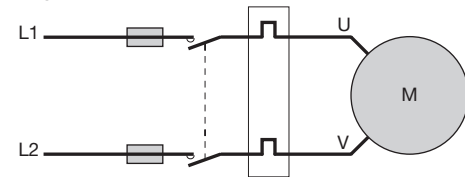

#### Three phase 400V

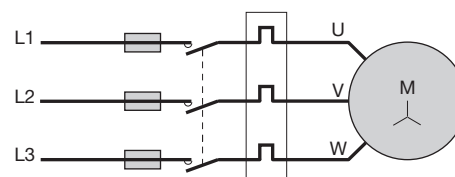

Maximum load in kW	Single phase with capacitor 230V	Three phase (AC3 cat.) 400V	Choice of contactor according to control diagram	
			2 wires	3 wires
	1.1		ES 220	
	2.2		ES 240	
				ES 320 - ES 420
				ES 340 - ES 345 - ES 440
				ES 365 - ES 463

### Requirements of use influence of working temperature:

derating factor between 40°C and 50°C : 0.9  
 example: heating with convector  
 the maximum load of ES 220 is 4.4kW for 50 000 operations  
 and for a temperature <40°C.  
 between 40°C and 50°C, the load is 4.4 x 0.9 i.e. 3.96kW

### Close fitting:

it is necessary to put a heat dissipation insert (reference LZ 060) between each contactor.

**Technical specifications**

	EH 010	EH 011	EH 110	EH 111	EH 171	EH 191
<b>Width in I 17.5mm</b>	1	1	3	3	3	5
<b>Version</b>	daily	daily	daily	daily	weekly	daily + weekly
<b>Electrical characteristics</b>						
voltage supply	230V +10/-10%					
frequency	50/60Hz					
consumption	0.5VA					
output	1NO		1 changeover			
<b>Switching capacity</b>						
AC1	16A/250V					
inductive load (cos phi = 0.6)	4A/250V					
incandescent lamps	900W					
<b>Characteristics</b>						
technology	Quartz					
dial	24 hours			7 days		24 hours and 7 days
min. switching	15 min			2 hours		15 min and 2 hours
max. number of switching	96			84		96/84
accuracy	+/- 1 sec per day					
supply failure reserve		200 hours		200 hours	200 hours	200 hours
reached in		120 hours		120 hours	120 hours	120 hours
manual override	auto/ON/OFF					
<b>Environment</b>						
ingress protection	IP20					
working temperature	-10 to +45°C					
storage temperature	-10 to +50°C					
connection	0.5 to 4□					

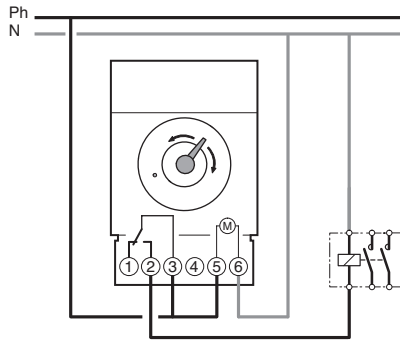

EH 110 Electrical connections

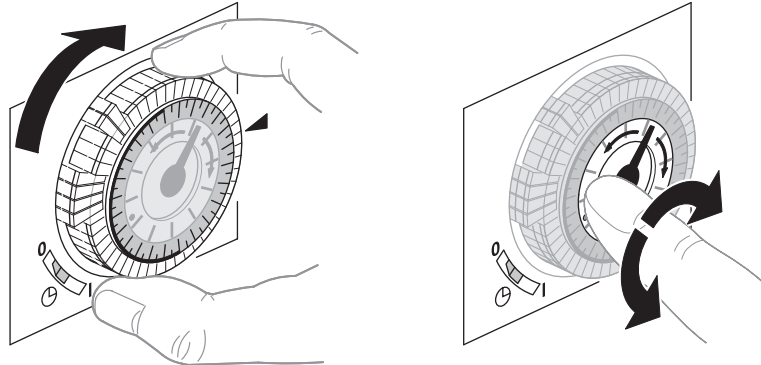

Simple time setting and programming using dual direction dial

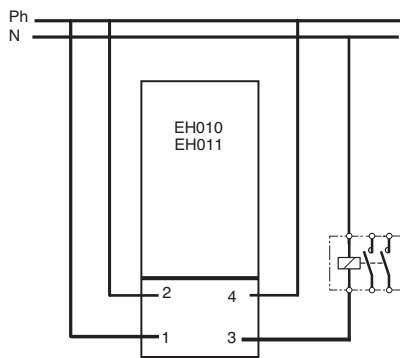

EH 010, EH 011 electrical connections

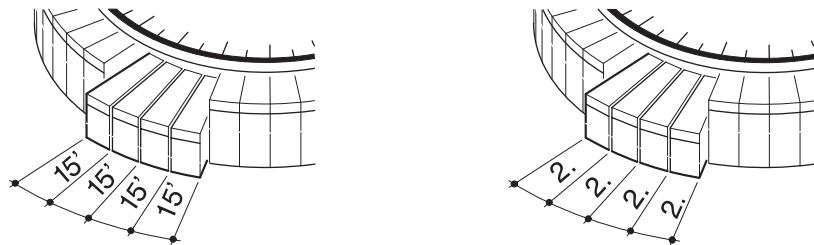

Programming by captive segments

## Technical data Analogue time switches 72 x 72 mm

Technical specifications	EH 710	EH 711	EH 770	EH 771	EH 712	EH 715	EH 716
<b>Dimensions (mm)</b>	72x72x48	72x72x48	72x72x48	72x72x48	72x72x48	72x72x48	72x72x48
<b>Electrical characteristics</b>	daily	daily	weekly	weekly	daily	daily	daily
voltage supply	230V +10/-15% 50/60Hz					110V to 240V AC 50/60Hz 48V DC +10/-15%	
consumption	0.5VA						
output	1 changeover				1 N/O	1 changeover	
<b>Switching capacity</b>							
AC1	16A/250V						
inductive load (cos phi = 0.6)	3A/250V						
incandescent lighting	1000W						
<b>Characteristics</b>							
technology	Quartz						
dial	24h		7 days		24h		
switching dial	10min		1 hour		10 min		
minimum switching	20min		2 hour		20 min		
working accuracy	+/- 1 sec per day						
supply failure reserve	-	200 hours	-	200 hours	-	-	200 hours
reached in	-	120 hours	-	120 hours	-	-	120 hours
manual switch	temporary ON or OFF						
<b>Environment</b>							
working temperature	-10 to +50°C						
storage temperature	-20 to +60°C						
connection capacity	1 to 6□						

Modular devices

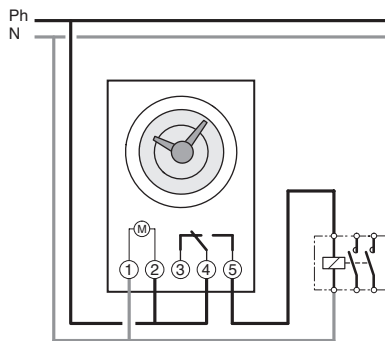

EH 710 Electrical connection

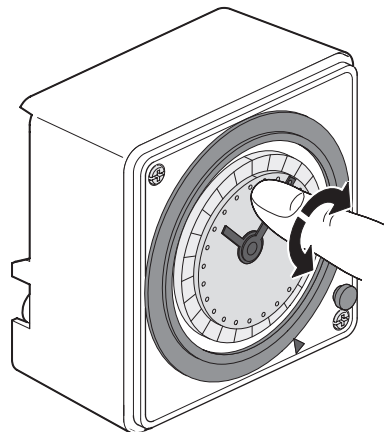

Very easy programming with dual direction dial

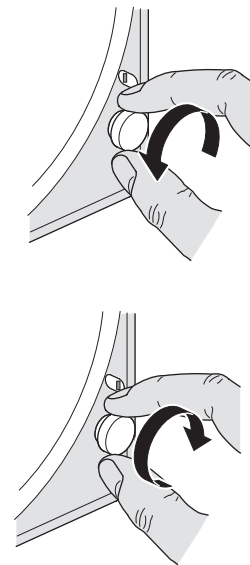

Manual override

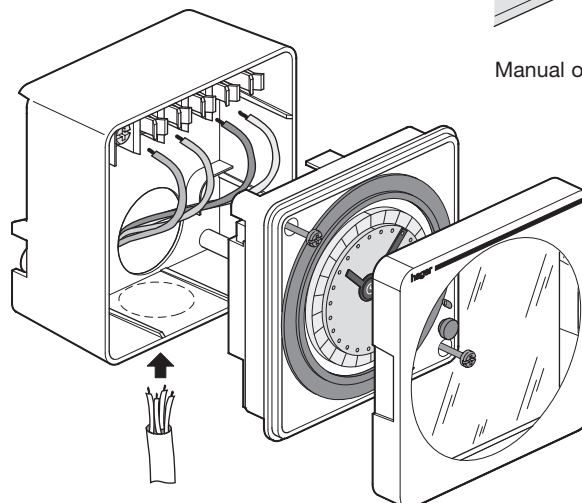
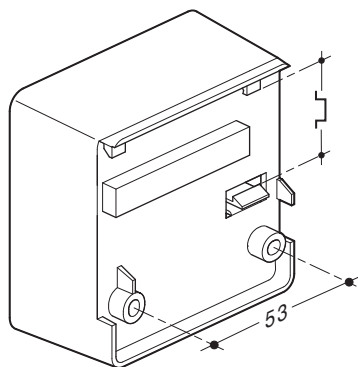
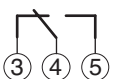
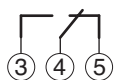
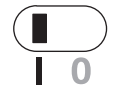

## Technical data Digital time switches

### Technical specifications

	EG 010	EG 110	EG 210	EG 071	EG 170	EG 171	EG 172	EG 270	EG 470
<b>Width in I 17.5mm</b>	1	3	3	1	3	3 (pulsed)	3	3	5
<b>Version</b>	daily	daily	daily	weekly	weekly	weekly	weekly	weekly	weekly
<b>Electrical characteristics</b>									
voltage supply	230V +15/-15% 50/60Hz		110/230V 50/60Hz +15/-15%	230V +15/-15% 50/60Hz			12V AC 50/60Hz 12V DC +15/-15%	110/230V 50/60Hz +15/-15%	230V +15/-15% 50/60Hz
consumption	1VA								20VA
output	changeover contact								
<b>Switching capacity</b>									
AC1	16A/250V								
inductive load (cos phi = 0.6)	3A/250V								
incandescent lamps	1000W								
<b>Characteristics</b>									
accuracy	+/- 1 sec per day								
supply failure reserve	Lithium battery total of three years								
manual override	permanent ON/OFF	permanent ON/OFF temporary ON/OFF	permanent ON/OFF	permanent ON/OFF temporary ON/OFF					
<b>Environment</b>									
ingress protection	IP20								
working temperature	-10 to +50°C								
storage temperature	-10 to +50°C								
connection	0.5 to 4□								

### Technical specifications

	EG 103B/E	EG 203B/E	EG 400
<b>Width in I 17.5mm</b>	2	2	4
<b>Version</b>	weekly	weekly	weekly / annual
<b>Electrical characteristics</b>			
voltage supply	230V+15% -15% 50/60Hz		230V+10% -15% 50/60Hz
consumption	max 6VA		0,5VA
output	changeover contact		changeover contact
<b>Switching capacity</b>			
AC1	μ16A/250V		μ10A/250V
inductive load (cos phi = 0.6)	μ10A/250V		
incandescent lamps	2300W		
<b>Characteristics</b>			
accuracy			
supply failure reserve	lithium battery : 5 years		lithium battery : 10 years
manual override			
<b>Environment</b>			
ingress protection	IP20		
working temperature	-5 to 45°C		-5 to +55°C
storage temperature	-20 to +70°C		-20 to +70°C
<b>connection</b>			
flexible	1 to 6□		1 to 4□
rigid	1.5 to 10□		1.5 to 10□

**Electrical connections**

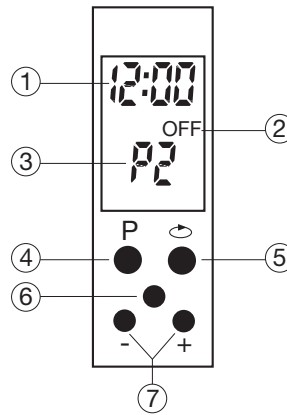
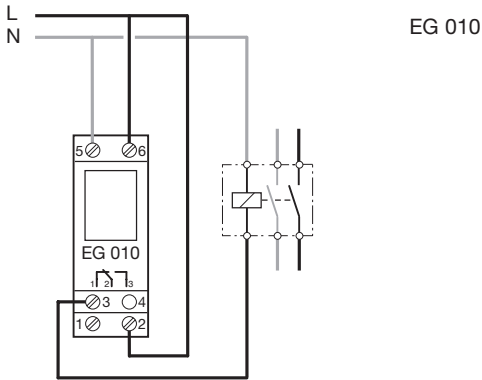

**Display :**

1. Time
2. Output contact (ON or OFF)
3. Program selected

**Buttons :**

4. To select the program to apply
5. To scroll program steps
6. Reset
7. + and - : change time settings

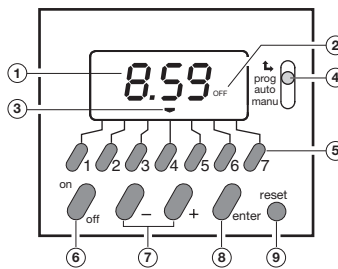
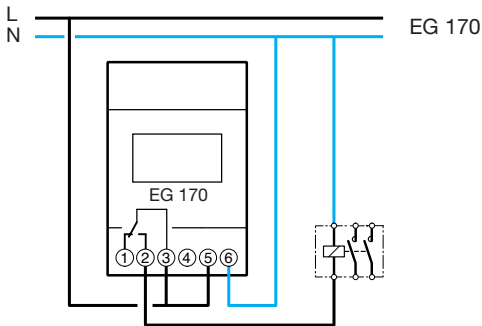

**Display :**

1. Time
2. Circuit status (ON or OFF)
3. Day of the week (1=Monday, 2= Tuesday,...)

**Buttons :**

4. Mode selector : to select one of the following modes :
  - time setting
  - programming
  - running mode
  - manual override
5. "1" to "7" : selection of the days
6. "ON/OFF" : chooses whether the circuits is ON or OFF.
7. "+" and "-" : changes settings
8. "enter" : to confirm selection
9. "reset"

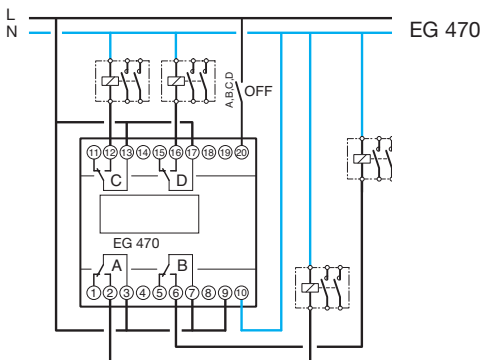

Modular devices

**Technical specifications**

**Electrical characteristics**

- supply : 230 V AC ± 15 %
- frequency : 50/60 Hz
- consumption : max. 6 VA at 50 Hz
- output : 1 changeover contact voltage free (EG 103B and EG 103E)  
2 changeover contacts voltage free (EG 203B and EG 203E)
- max. breaking capacity :  
AC1 : μ16A 250 V~  
DC1 : μ4A 12 V ~  
Cos φ = 0,6 : μ10A 250 V~
- incandescent lamps : 2300 W
- halogen lamps : 230 V : 2300 W
- compensated fluorescent lamps // (max. 45μF) : 400 W
- non compensated fluorescent lamps, compensated in series : 1000 W
- fluo compact lamps : 500 W
- min. breaking capacity :  
AC1 : 100 mA 250 V~  
DC1 : 100 mA 12 V ~
- galvanic insulation between supply and output

**Functional characteristics**

- programming capacity : 56 steps shared on the 2 ways for EG 203B and EG 203E
- min. time between 2 steps : 1 minute
- accuracy : ± 1,5 sec / 24h
- supply failure reserve : lithium battery total of 5 years of supply failure
- the product switches to watching state (display lighted of) after 1 min without power. It returns into Auto mode at return of power or by push on a button
- ingress protection : IP 20







**Environment**

- working temperature : -5 to +45 °C
- storage temperature : -20 to +70 °C

**Connection by cage terminals**





- flexible : 1 to 6 □
- rigid : 1,5 to 10 □

**Main characteristics**

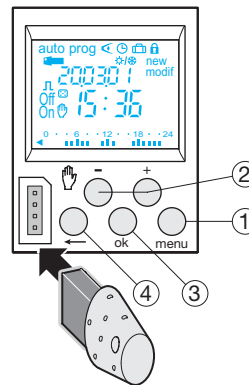
- product delivered and updated to current date
- automatic change of time schedule summer:winter ☀ / ❄
- programming key :  for temporary override
- for the copy or the saving of the programme
- programming per day or group of days
- 56 programmes steps ON, OFF or impulse  : 1 sec to 30 mn. (EG 103E and EG 203E)
- permanent priority ON or OF  fixes),
- temporary overrides ON or OFF  blinking),
- holidays mode  priority setting ON or OFF between two dates (EG 103E and EG 203E) ,
- presence simulation  (EG 103E and EG 203E)
- barregraphe of visualization of the daily profile
- possibility of locking the keyboard 
- programmable power off
- backlighted screen (EG 103E and EG 203E),
- remote controled temporary overrides (EG 103E).



**Product presentation**



- ① menu : selection of the operating mode  
auto : functioning according to the established program  
prog : new for the programming  
prog : modif to modify an existing program
-  : checking of the program
-  : modification of the hour, the date and the choice of the mode of change of the time schedule summer/winter ☀ / ❄
- ②  : holidays (EG 103E and EG 203E)
-  and - : navigation or adjustment of the values in Auto mode, selection of priority settings, overrides or of random functioning (EG 103E and EG 203E)
- ③ ok : to validate the blinking info
- ④  : return at the preceding step

You can return in Auto mode at any time with the menu key. If no action is made during 1 min, the switch returns into Auto mode.

**Reset :**

- of programme : it can be completely delated by simultaneous push on the 3 following keys : menu, ok and  . the hour and the date are maintained
- Total : by simultaneous push on menu and ok keys and  , the whole content of the product is removed. After a total reset, it is necessary to redefine the hour and the date.

**Electrical connection**

**EG 103B**

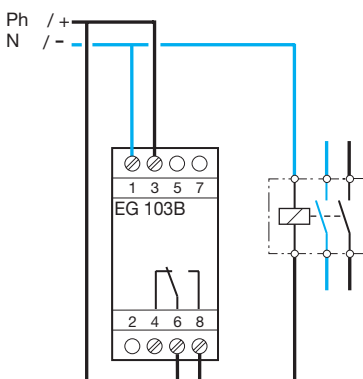

**EG 103E**

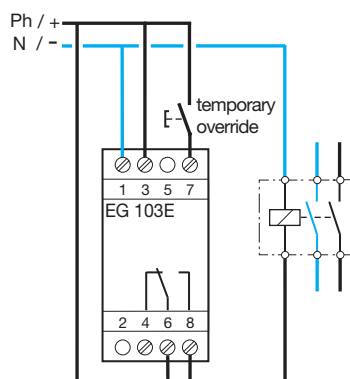

**EG 203E / EG 203B**

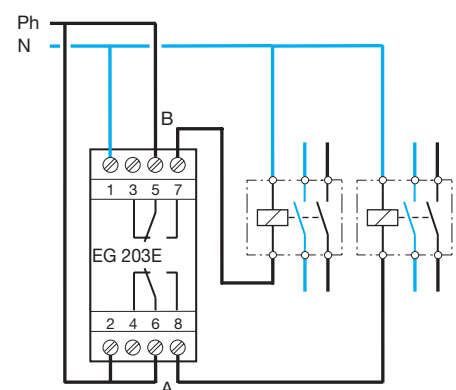

**EG 400 programmer**

**Electrical characteristics**

- supply : 230 V +10 -15% 50/60 Hz
- consumption : 0,5 VA
- output : 3 changeover switches and 1 normally open contact  
μ 10 A - 250 V~ AC1

**Functional characteristics**

- weekly and annual cycle
- programming capacity : 102 program steps
- precision of programming : 1 minute
- functioning precision : ± 1 sec / day
- supply failure reserve :  
lithium battery total of 10 years  
display disappears at power supply cut (hour, date, program remain memorized)

**Environment**

- working temperature : -5 at +55 °C
- storage temperature : -20 at +70 °C

**Connection capacity :**

- flexible: 1 to 4 □
- rigid : 1,5 to 6 □

**Main characteristics**

- **Change of time schedule summer/winter :**  
switch to the winter or summer times is pre-programmed for the last Sunday of March and of September.  
Possibility to modify or inhibit these dates if necessary.
- **Programming of 15 weekly cycles :**  
of different overrides from the basic cycle; these subprogrammes can be assigned to the various ways.
- **Possibility of priority settings ON or OFF :**  
permanent :  
- by maintaining push on the button corresponding to the way  
- by programming of date by date  
temporary :  
- by brief push on the button corresponding to the way
- **Functioning by impulse :**  
programmable for a maximum duration of 59s
- **Grouping of days and ways :**  
setting in memory of common instructions to several days and several ways in order to save program steps.
- **Display of the number of free steps for programming**

**Presentation**

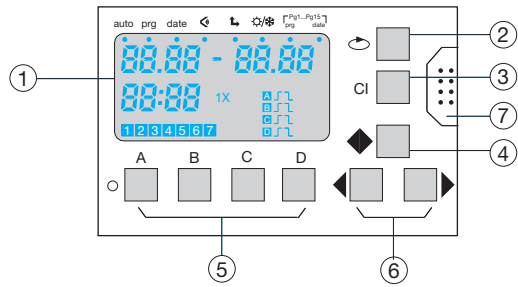

- ① liquid crystal display screen
  - ② selection button for the various modes  
Auto : automatic  
Prg : programming  
Date : priority setting ON or OFF programmable date by date  
◀ : visualization  
▶ : setting of hour and date  
☀ / ❄ : modification of the dates of time changing for winter and summer
  - ③ partial deleting
  - ④ according to mode :  
- button for incrementing  
- button for assignment of days and ways  
- button for choice of the state of the instruction
  - ⑤ priority setting of the ways
  - ⑥ scroll buttons
  - ⑦ connector for key EG 002
- Pg1..Pg15 : program weekly override

**Electrical connection**

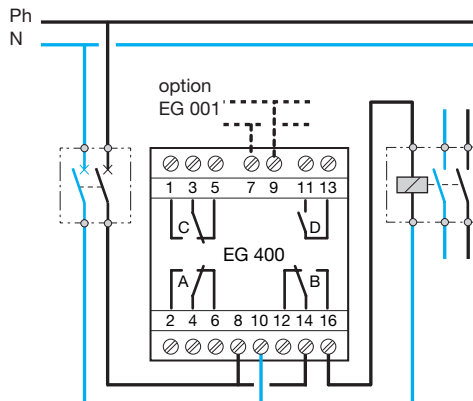

Technical specifications	
	EE 180 (1 channel)   EE 181 (2 channels)
Width in I 17.5mm	2   2
Supply voltage	230V AC (+10% / -15%), 50/60Hz
Number of output	1   2
Characteristics of relay	change over contact 16A AC1 250V /10A cos phi = 0,6
Incandescent	2300W
230V-halogen	2300W
Connection	terminal n° 5
Flexible	1 to 6□
Rigid	1,5 to 10□
<b>Environment</b>	
Storage temperature	-20°C to +60°C
Working temperature	-10°C to +55°C
IP and IK	IP 20 IK 3
Standards	CE + CTICK and CEI 60-669
<b>Functional characteristics</b>	
Display LCD	without backlighed screen
Operating reserve	Lithium battery 5 years
Precision	+/- 1,5s/day
Programming key	yes
Automatic change of winter/summer time	yes
Functions available in free programming	weekly programming / permanent override / temporary override
<b>Astro functions</b>	
Astro mode	yes   Independent programming for each channel
Programming of the lighting interruption	yes (if channel ASTRO)
Temporary override	15 / 30 / 60min.
Maintained ON	adjustment common to the 2 channels
Anticipation ON	adjustment common to the 2 channels

**Electrical connection :**

**Presentation :**

EE180 : 1 channel

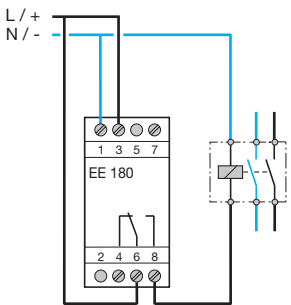

EE181 : 2 channels

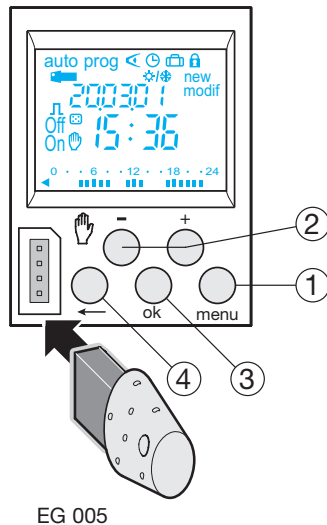
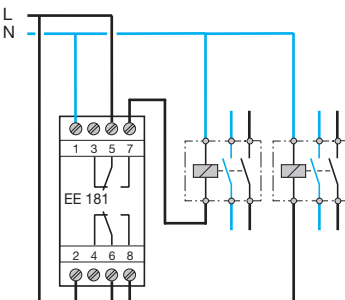

**Keys:**

- ① **menu** : selection of operating mode
- auto** : mode of running according to the program selected.
- prog** : new for programming mode.
- prog** : **modif** to modify an existing program.
- ← : checking of the program.
- ↻ : modification of time, date and selection of the winter / summer time change mode ⚙️/⚙️.
- astro** : astronomical mode.
- ☆ : indicates that the channel is in astronomical mode
- ② **+ and -** : navigation or setting of values.
- A 🖐️ : in **auto** mode, selection of overrides,
- b 🖐️ or waivers .
- ③ **ok** : to validate flashing information on display.
- ④ ← : to return to the previous step.

You may return into **auto** mode at any moment using **menu**.

If no action is taken for 1 min, the switch returns into **auto** mode.

**Technical specifications**

	EE 100	EE 101	EE 110	EE 170	EE 171
<b>Width in I 17.5mm</b>	3	3	5	3	3
<b>Electrical characteristics</b>					
voltage supply	230V +10/-15%				
frequency	50Hz				
consumption	1.5VA maximum				
output	1 voltage free changeover contacts				
<b>Maximum switching capacity</b>					
AC1	16A / 250V				
incandescent lamps	2000W				
230V halogen lamps	1000W				
fluorescent lamps	1000W				
non compensated	1000W				
fluorescent lamps, compensated	200W				
in series	1000W				
duo fluorescent lamps	1000W				
<b>Functional characteristics</b>					
lighting level : 2 ranges	5 to 100 lux and 50 to 2000 lux				
ON and OFF delay	15 to 60 seconds				
mounting of cell	surface	flush *	surface	surface	surface
programmable	no	no	yes	yes	yes
technology			electromechan.	digital	
cycle			24 hours	7 days**	7 days
programming setting			15 min.	1 min.	1 min
accuracy			+/- 6min/year	+/-6min/year	+/-6min/year
operating reserve			accu 200h after beeing connected for 120h	lithium battery total of 3 years of supply failure	lithium battery total of 3 years of supply failure
<b>Environment</b>					
working temperature	-30°C to +60°C (cell) -10°C to +50°C (modular device)				
storage temperature	-20°C to +60°C				
<b>Connection</b>					
maximum length between cell and modular device	50 meters				
capacity (modular device)	0.5 to 4□				
capacity (cell)	0.75 to 4□		0.75 to 4□		

Note : \* delivered with a 1m cable (2x0.75□)  
\*\* 8 predefined programs

Cells	EE 002	EE 003
Type	flush mounting	surface mounting
Dimension (mm)	89x48x32	25x25x20 hole Ø 25mm
Connection	cable 1m 2x0.75□	0.75 to 4□
Ingress protection	IP54	IP54
Working and storage temperat.	-30°C to +60°C	-30°C to +60°C

**Wiring diagram**

EE 100 - EE 101 - EE 171

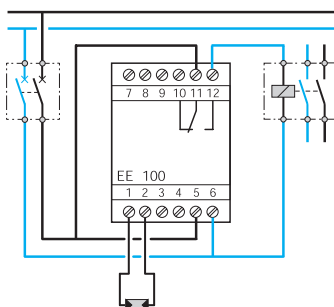

EE 110

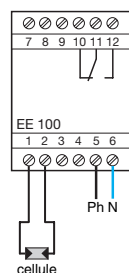

**Technical specifications**

	<b>EE 701</b>	<b>EE 702</b>
	<b>Compact light switch basic 10A</b>	<b>Compact light switch enhanced 16A</b>
<b>Dimensions</b>	80 x 40.5 x 95	
<b>Supply voltage</b>	230V AC (+10%/-15%), 50Hz	
<b>Characteristics of relay</b>	NO contact 8A AC1	NO contact 16A AC1
Incandescent	1000W	2300W
Halogen ELV (12 or 24V) via ferromagnetic or electronic transformer	750 VA	1500 VA
Non compensated fluorescent tubes	12x20W	20x20W
Compact fluorescents	1000W	2000W
Electronic ballast	8x58W	16x58W
<b>Connection</b>		
flexible	1 to 6□	
rigid	1.5 to 10□	
<b>Environment</b>		
Storage temperature	-30°C to +60°C	
Operating temperature	-25°C to +45°C	
IP / IK	IP55 / IK03	
Isolation class	II	
<b>Standards</b>	NFC 15 100 - IEC 60364-1-EN 60669-2-1	
<b>Functional characteristics</b>		
Lighting switching-on level	Fixed (lighting switching-on level : 10 lux / lighting switching-off level : 30 lux	Setting by potentiometer from 2 to 1000 lux hysteresis 10%
Setting delay	40 seconds	Setting by potentiometer from 1 to 120 seconds
Tripping delay	120 seconds	
Mounting	on wall / on round box / on pillar	

**Electrical connections**

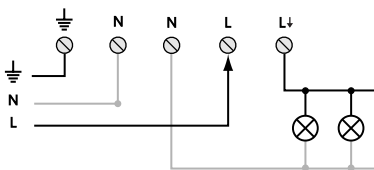

**Dimensions**

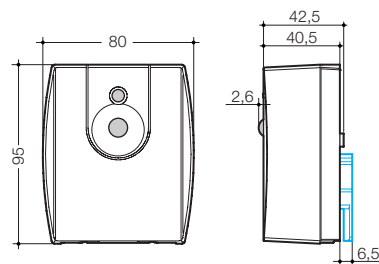

EE810/EE811/EE812  
detection areas

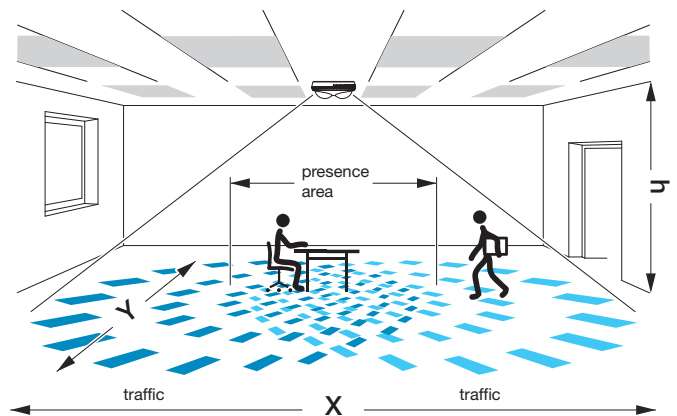
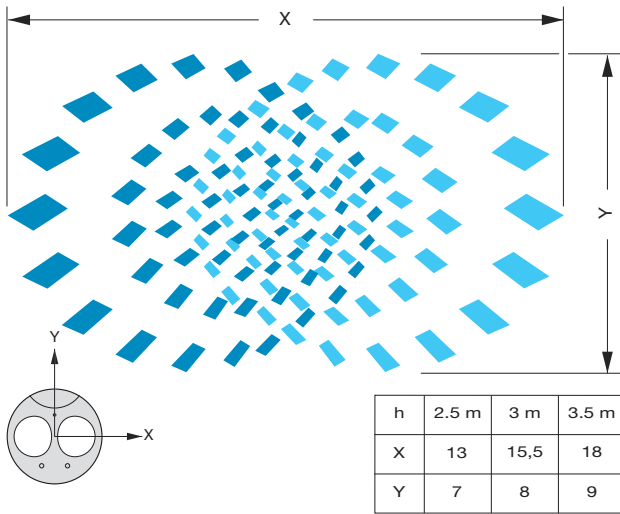

Modular devices

Description

Lighting time delay adjustment potentiometer

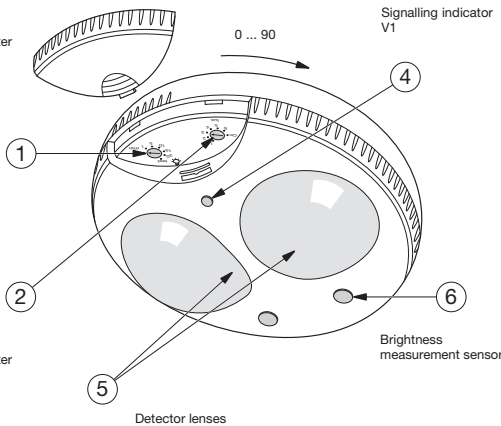

Brightness threshold adjustment potentiometer

Detector lenses

Adjustment potentiometers

EE810

EE811 / TX510

EE812 / TX511

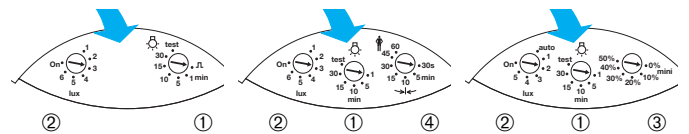

- ① on delay ② light regulation
- ③ residual lighting ④ time delay with the interlocking (output 2)
- mode 1 : potentiometer > 10 s = time delay with the interlocking 15 min (use : correction of the setpoint, heating, etc.)
- mode 2 : potentiometer ≤ 10 s = time delay with the interlocking 15 s (use : ventilation/ventilation, synoptic lighting, ...)

Technical specifications

ref.	EE810	EE811	EE812
type	presence detector	presence detector	presence detector
	1 channel	2 channels	1/10V
supply voltage	230V~ +10%/-15% / 50Hz		
settings :	output brightness 1/3 potentiometer : auto (400 Lux) 5 to 1200 Lux, OFF output temporisation 1 potentiometer : 1 - 30 min, test, impulsions (EE810) output temporisation 2/3 potentiometer : 30 s - 1 h		
residual brightness	-	-	Potentiometer 0-50%
breaking capacity output 1 (lighting)	16 A AC+, incandescent lamps, halogen : 1500 W fluo with electronic ballast: 580 W fluo parrallel compensated : 290 W/32µF		10A AC1
output 2 (presence)	- 2A AC1		
output 3 (brightness setting)	-		1-10V current : 50 mA
input command 50 m max.	230V commutation		230V commutation/dimming
LED	OFF, auto, ON : movement/test		
power consumption	1,2 W	1,1 W	1 W
ingress protection	IP41		
connection	1 - 4 mm <sup>2</sup>		
temperature	storage : -10°C to +60°C working : 0°C to +45°C		

Test mode :

this mode makes it possible to validate the detection area :

- potentiometer ① in position "test"
- indicator V1 - ④ will indicate any detection by lighting for one second if the level of illumination is lower than the preset threshold. This lighting output S1 is not controlled in this mode, the time settings will remain ignored.

Instances of lighting levels

position of potentiometer	Lux value	Application
1	5	-
2	100	corridor
3	200	corridor, WC
4	100	VDU work
5	500	offices
6	800-1200	classrooms laboratory
ON	measurement of brightness @inhibited	

regulation set point is set at 400 Lux

**Measure lighting**

In addition to one density of higher detection, the difference between one presence detector and a conventional detector of movements reside at the level of their principle of detection. The detector of movements will be activated in the event of detection of movements in the darkness. If the latter is transformed into lighting during the capture, the detector of movements will not extinguish however the light. One presence detector must be able to fill of such tasks and to make the difference between the natural and artificial light.

The measurement of lighting carried out since the ceiling can be different from the measured lighting, because it will be influenced by the provision of the windows, the form and the reflective properties of the walls and the pieces of furniture, etc measurement moreover will be delayed in order to avoid inopportune commutations.

**Presence detection**

based on a solution patented by hager, the optical part presence detection rests on a double lens making it possible to obtain a zone of rectangular capture of form. The head of the detector can also swivel to adjust the detection zone. The latter is subdivided in two sections equipped with a density higher than the center and a density to reduce in the direction length. in the offices, these detectors should thus be assembled directly above the places of work, resp. in the direction length for an installation in corridors (zones of circulation).

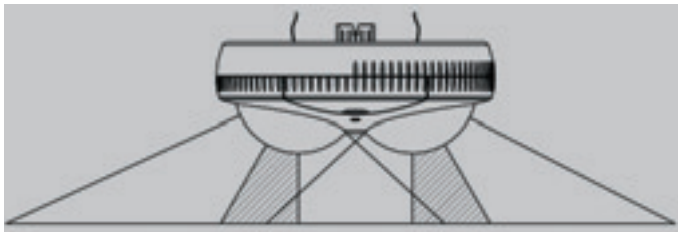

movement detection	presence detection	movement detection
13 x 7 m (installation max. high 2,5 m)		

**Detection zone**

Covering a rectangular detection zone of 13 x 7m, the Hager presence detectors represent an ideal solution for the offices, classrooms, toilets, corridors, markets and garages. In the event of assembly of two detectors in order to increase the range of detection, it is then recommended to respect a zone of covering of approximately a meter. Only two detectors will be thus necessary to cover a 25m length maket. A possibility of circuit Master/Slave exists for the commutation of only one group of luminaries. The presence detector principal one (Master : EE812 or EE811) measurement the lighting and the presence, then commutates and controls the electric consumers. Auxiliary presence detectors (Slavic : EE810) detect only the presence and will presence detector announce this one to principal, which will carry out commutation then by taking account of the lighting. The diagrams of wiring are illustrated in the respective instructions.

**Assembly**

The behavior of commutation will be determined by the passage of people in the zone of capture of the detector. In exceptional cases, an inopportune commutation can be caused by various influences. The sources of potential parasites should already be evaluated during the study of the project, resp. eliminated before the assembly.

obstacles decreasing the range of the detector :

- the partition walls, plants or racks, etc can limit the range of detection.

Simulated movements :

- the presence detectors capture fast modifications of temperature in the environment of the detector as being movements, for example at the time of or the stop starting of lowers with hot air, ventilators etc when the flow of air is directed directly on the lenses or of the objects near the zone of capture of the detector.
- objects being heated slowly do not have a negative influence and do not cause inopportune commutation. A side distance > 0,5m should however be respected. Proximity of the conduits of heating and the bodies of radiators.
- luminaries switching on themselves and dying out near the zone of detection can simulate a displacement (p e.g of the lamps incandescence or halogen located at a distance < 1m).
- objects moving such as mobile machines, robots, posters can also cause an inopportune detection.

detection zone - scale 1:100

assembly height 2,5 m

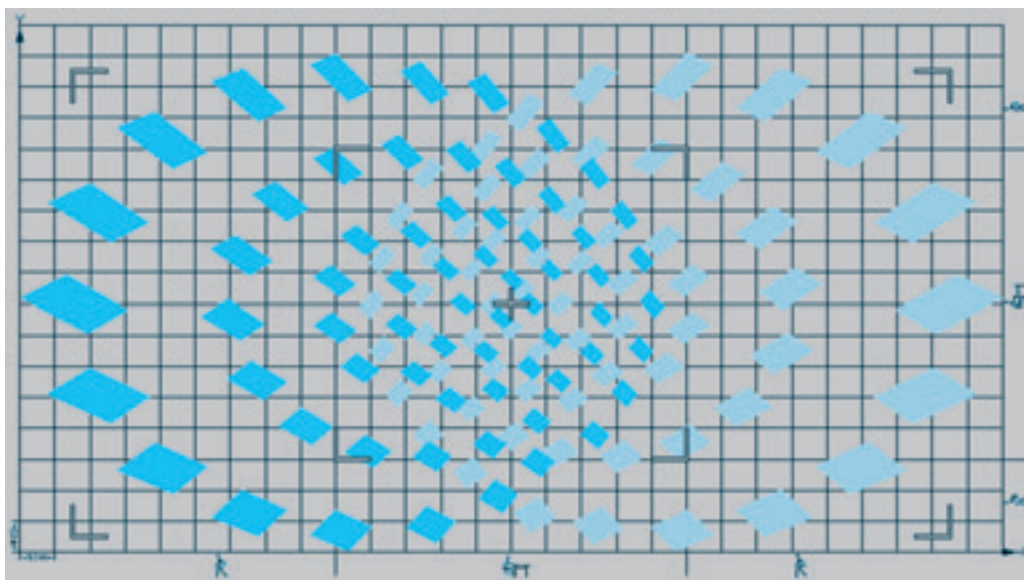

### Technical specifications

	EE 810	EE 811	EE812
<b>Designation</b>	Presence detector 1 channel	Presence detector 2 channels	Presence detector (light regulator) 1/10V
<b>Settings</b>			
Lux level channel 1	Potentiometer : 5 to 1200 Lux, Lux ON + auto for EE812		
On delay channel 1	Potentiometer : 1 min...30 min + pulse for EE810		
On delay channel 2	-	Potentiometer : 30s-1h	
Min level	-	-	Potentiometer 0-50%
<b>Electrical data / functional data</b>			
Channel 1 (light)	16A AC1 incandescent bulbs : 1500W halogen 230V : 1500W fluo. parallel compensated : 290W/32F fluo. with electronic ballasts : 580W		μ10A AC1  fluo with electronic ballasts : 580W
Channel 2 (slave)	Triac output 0,8A maxi	-	-
Channel 2 (presence)	-	μ2A AC1	
Channel (light regulation)	-	-	1-10V 50mA
Control input (push button)	-	230V toggle	230V toggle/dimming
LED	OFF : auto, ON : for test purpose		
Power supply	230V +10% / -15% / 50Hz		
ingress protection	IP41		
Power consumption	1,2W	1,1W	1W
Wiring	Terminals : 1 to 4□		
<b>Environment</b>			
Storage temperature	-10°C to +60°C		
Working temperature	0°C to 45°C		

**EE810**

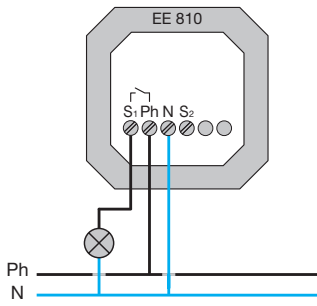

**EE811**

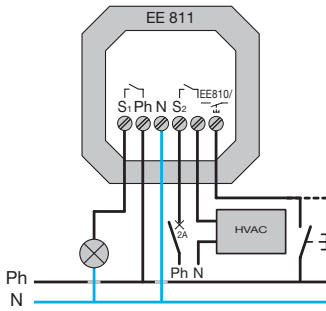

**EE811 Master + EE810 Slave**

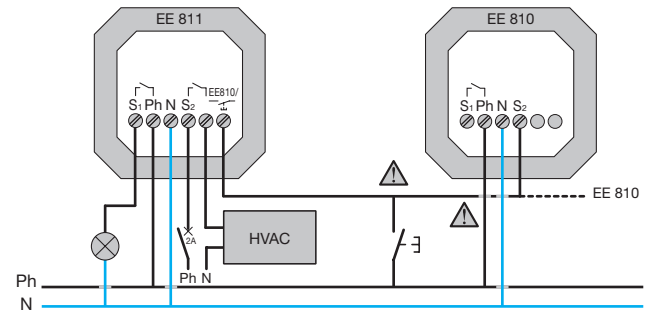

**EE812 + ballast, EE812 + EV100 / EV102**

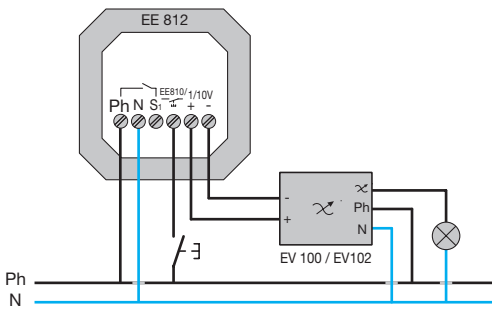
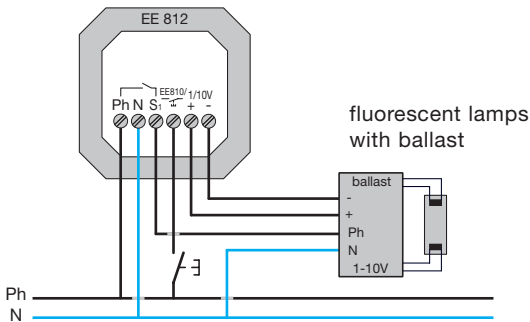

**EE810 + EM001N / EM003**

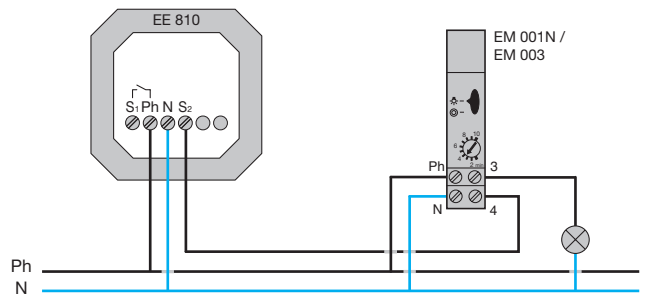

**EE812 Master + EE810 Slave**

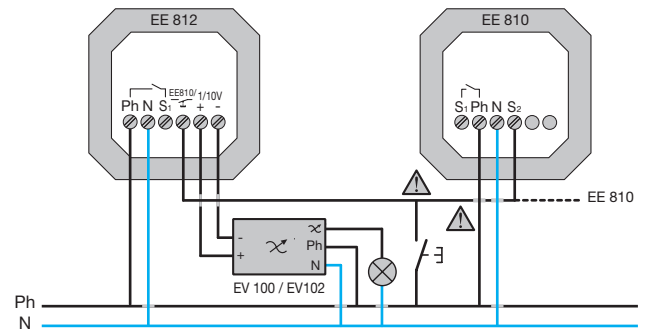

**Apparent assembly**

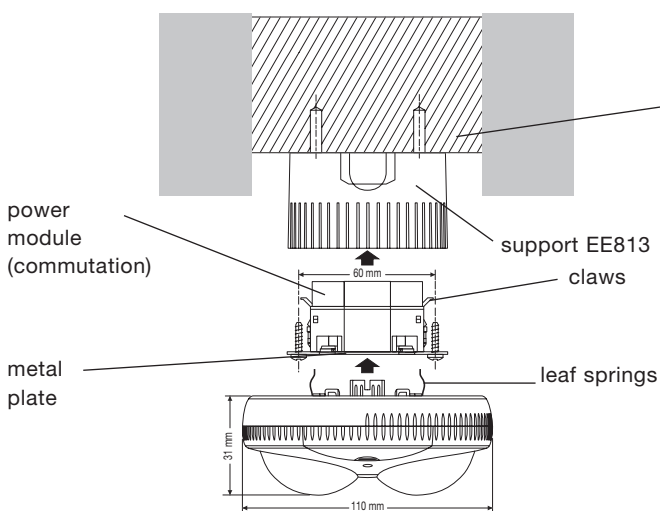

**Flush-mounted assembly**

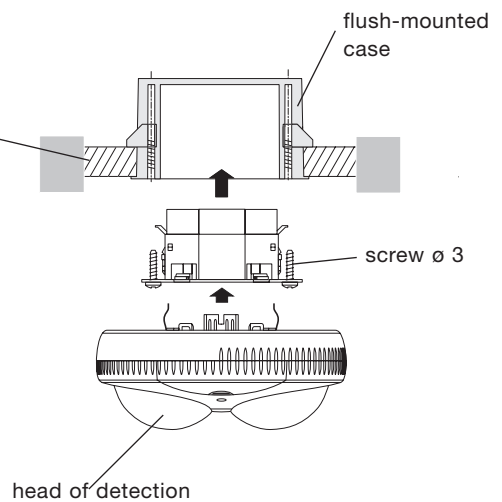

**Technical specifications**

	EZ 001 - EZ 002 -EZ 003 - EZ 004 - EZ 005 - EZ 006
<b>Electrical characteristics</b>	
<b>Supply voltage</b>	24-28 Vdc (+10% - 15%) terminals A1 & A2 24-230 Vac (+10% - 15%) terminals A1 & A2 12 Vac & dc (+10% -10%) terminals A3 & A2
<b>Output</b>	1 volt free C/O contact
<b>Life expectancy</b>	
max load AC1	10A / 230V~ 50,000 cycles
incandescent	450W~ 100,000 cycles
fluorescent non comp.	600W~ 50,000 cycles
inductive load 0.6pf	5A / 230V~ 100,000 cycles
<b>Min power</b>	
AC	100mA at 230V
DC	100mA at 12V
<b>Galvanic isolation</b>	2kV
<b>Standard / norm</b>	EN60669-2-1
<b>Functional characteristics</b>	
<b>Timer range</b>	0.1s - 10 hours
<b>Min. command period</b>	
AC	50ms
DC	30ms
<b>Operating temperature</b>	
working	-20°C to +50°C
storage	-40°C to +50°C
<b>Connection capacity</b>	
flexible	1 - 6□
rigid	1.5 - 10□

Modular devices

**Functional characteristics**

**EZ 001, EZ 003, EZ 005, EZ 006 (functions D,E,F)**

Cd: command.  
O: output.  
T: time delay.

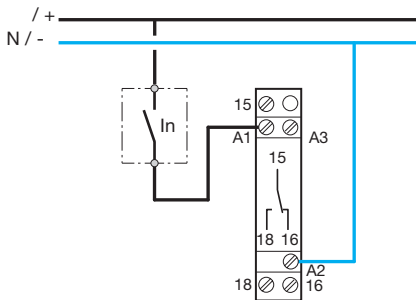

12V supply :  
between terminals A3/B1 and A2

**EZ 002, EZ 004, EZ 006 (functions A,B,C)**

indicator light (for versions with NO contact).  
ON  
OFF

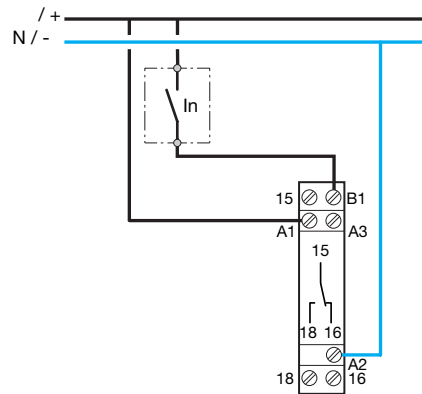

12V supply :  
between terminals A3 and A2

**Each time delay bracket is divided into 4 ranges**

Time delay brackets	1s to 1h	0.1min to 10h	0.1s to 10min	0.2min to 20h
<b>Ranges</b>	1s to 10s 0.1min to 1min 1min to 10min 0.1h to 1h	0.1min to 1min 1min to 10min 0.1h to 1h 1h to 10h	0.1s to 1s 1s to 10s 0.1min to 1min 1min to 10min	0.2min to 2min 2min to 20min 0.2h to 2h 2h to 20h

**Environment**

working temperature: -10°C to +60°C.  
storage temperature: -20°C to +70°C

**Delay on**  
EZ 001 & EZ 006 function D

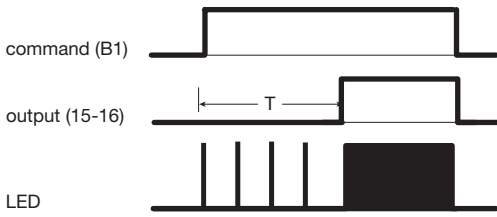

**Delay off**  
EZ 002 & EZ 006 function C

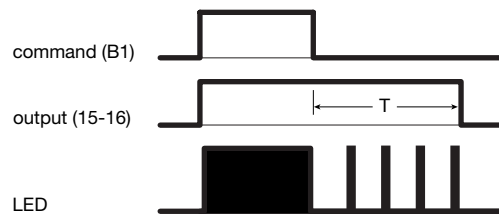

**Adjustable time on**  
EZ 003 & EZ 006 function E

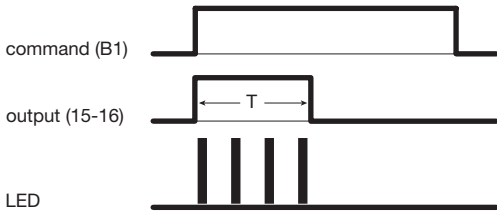

**Impulse timer**  
EZ 004 & EZ 006 function A

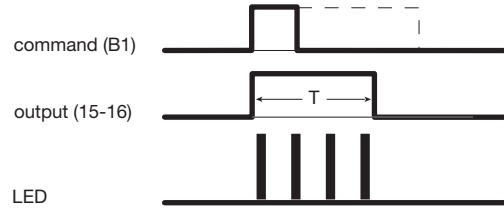

**Symmetrical flasher**  
EZ 005 & EZ 006 function F

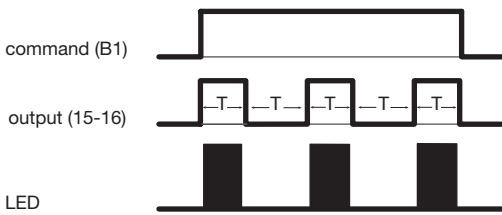

**Multifunction timer**  
EZ 006 function A

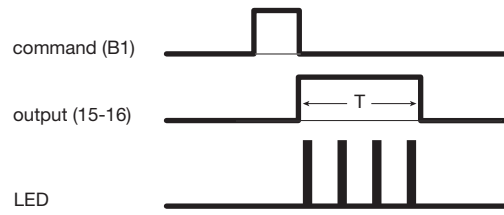

Multifunction timer - 8 individual functions

- A = timer.
- B = delay off (output relay opens either at end of command or after set time period - which ever is shorter).
- C = delay off.
- D = delay on.
- E = delay on (output relay closes either at end of command or after set time period - which ever is shorter).
- F = Symmetrical timer.



On selection - contact permanently closed  
Off selection - contact permanently open

- Output relay open - with no command
- ||||| Output relay open - with command signal running
- ▬ Output relay closed - with command signal running
- ▬▬▬▬ Output relay closed - with command signal removed
- ▬▬▬▬ Output relay closed (EZ 005)

**Technical information EMN switches**

Technical data	EMN 001 / EMN005
Mains supply	230 V AC (+10 % / -15 % ), 50 Hz / 60 Hz
Contact	 μ16A – 250V AC1
Consumption	< 5VA / <1W
Size	83 x 60 x 17.5 mm
IP	20
Terminals	With screw:                    1 → 6 mm <sup>2</sup> 1,5 → 10 mm <sup>2</sup>

**Load type**

Incandescence /Halogen 230V 	2300 W
Halogen VLV associated with ferromagnetique transformer 	1500 W
Fluorescent lamps // with electronic or ferromagnetique transformer	1000 VA / 110μF
Fluorescent lamps Mono/Duo	1000 W
Fluo Compact Lamps	460 W

**Functional characteristics**

Time delay	30 seconds to 10 minutes / 1 hour by pressing the push button more than 3 seconds
Retrigger	Yes
Local command	Automatic / override ON
Max. current in rest position	100 mA
Automatic 3/4 recognition	Yes
Working temperature	- 10°C to + 50°C
Storage temperature	- 25°C to + 70°C
Standards	EN 60669-1, EN 60669-2-1, EN60669-2-2 et EN 60669-2-3

**Technical specifications**

**Electrical characteristics**

- supply voltage : 230 V
- load time : 36 h

**Functional characteristics**

- autonomy / load 24 hours : 1 hour
- autonomy / load 36 hours : 1,5 hours
- working life : 500 cycles
- illumination at 1 m : 4 lumens
- illumination at 0,5 m : 16 lumens

**Environment**

- working temperature : 0 to +40 °C
- storage temperature : -5 to +50 °C

**Connection capacity :**

1 to 4 mm<sup>2</sup>

With emergency light EE 960, you will always have a small pocket lamp :

- easy to find : the device is always on the board
- battery always loaded

**Functional chart**

voltage supply 230V	position of switch	state of LED	state of lamp
supply 230V	« 0 »	on red	off
	« 1 »	on green	off
no supply 230V or lamp removed from socket	« 0 »	off	off
	« 1 »	off	on

**Electrical connection**

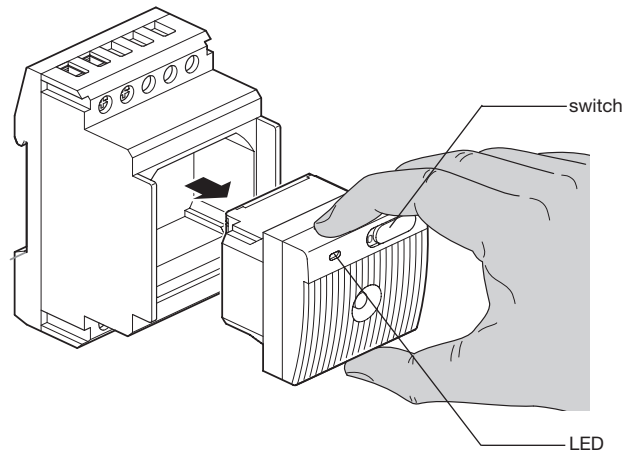
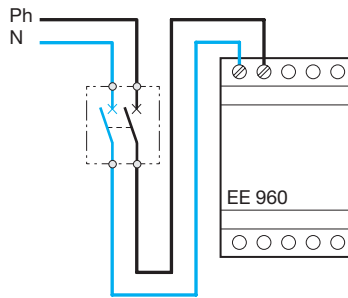

**Remote control EE 905 - EE 910 (emergency lighting)**

**Technical specifications**

**Electrical characteristics**

- supply voltage : 230 V +10 -15% 50/60 Hz
- output impulse for control  
EE 905 : 8,4 V  $\square$ , EE 910 : 12 V  $\square$
- consumption : EE 905 = 3 VA  
EE 910 = 4 VA

**Functional characteristics**

- number of remotable blocks  
EE 905 : 60  
EE 910 : 120

**Environment**

- working temperature: -10 to +40 °C
- storage temperature : -20 à +80 °C

**Connection capacity :**

- flexible: 1 to 6  $\square$
- rigid : 1,5 to 10  $\square$

**Electrical connection**

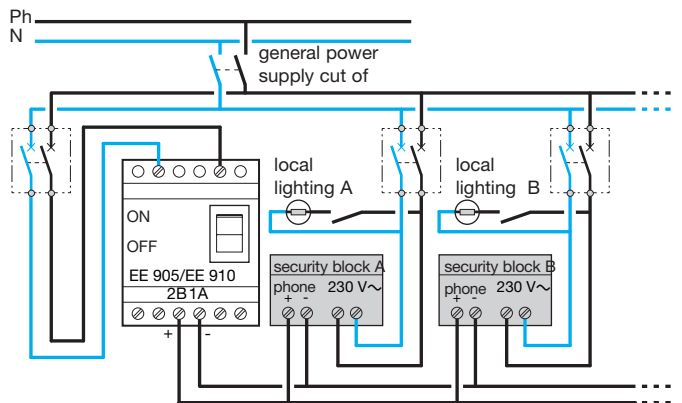

**Choice of dimmers according to : lighting sources, dimming ranges and other characteristics**

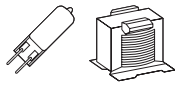
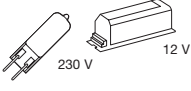
lighting source	functioning of a standalone product						functioning in a system (association of dimmers)
	0 W	20 W	60 W	100 W	300 W	600 W	1000 W
halogen or incandescent 230 V 		EV 011, EV 012					
		EV 002, EV 004					
		EV 100, EV 102				EV 102 (Master position) + x EV 100 ou EV 102 (Slave position)	
VLV halogen lamps supplied by ferromagnetic transformer 		EV 011					
		EV 002, EV 004					
		EV 100, EV 102				EV 102 (Master position) + x EV 100 ou EV 102 (Slave position)	
VLV halogen lamps supplied by dimnable electronic transformer 230V (cos φ ≥ 0,95) 		EV 012					
		EV 002, EV 004					
		EV 100, EV 102				EV 102 (Master position) + x EV 100 ou EV 102 (Slave position)	

Modular devices

**Choice of pilot dimmers for direct control via 1/10V transformers or electronic ballast**

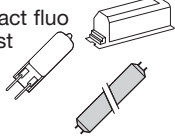
light source	0 W	30 kW
VLV halogen lamps supplied by 1/10V variable transformer fluorescent lamps or compact fluo lamps with electronic ballast variable in 1/10V 	EV 106* pilot 1/10 V	
	EV 108* pilot 1/10 V multi-dimming (a call of memorised levels)	
	* conditions to respect : a) $\Sigma I$ (ligne 1/10 V) < 50 mA b) $\Sigma I$ (ballast + lampe) < 10 A / AC1	
	example : for the lighting of a hall 30 tubes of 2x36W are requested characteristics of used ballasts : $I$ (ligne 1/10 V) = 1 mA $I$ (ballast + lampes) = 0,31 A calculation : $\Sigma I$ (1/10 V line) = 30 mA < 50 mA $\Sigma I$ (ballast + lamp) = 9,3 A < 10 A	
	after checking, 1 x EV 106 or EV 108 can pilot this installation	

**Choice of dimmers for functioning in a system**

to control high powers	dimmer EV 102 (Master position) + pilot dimmers EV 100 and/or EV 102* (Slave position)
	* conditions to respect : a) $\Sigma I$ (1/10 V line) < 50 mA or maximum 30 dimmers
	example : total power to dim : 8,6 kW requested products: 1 x EV 102 and 8 x EV 100 = 9 kW

**Dimensions**

dimmers EV 100 and EV 102

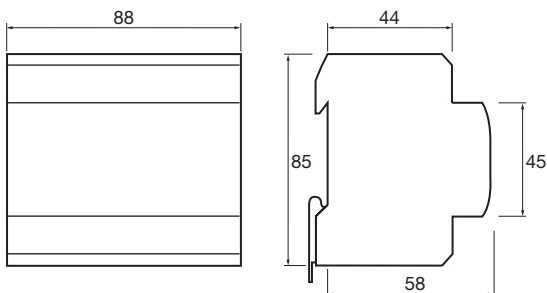

dimmers EV 002, EV 004, EV 106 and EV 108

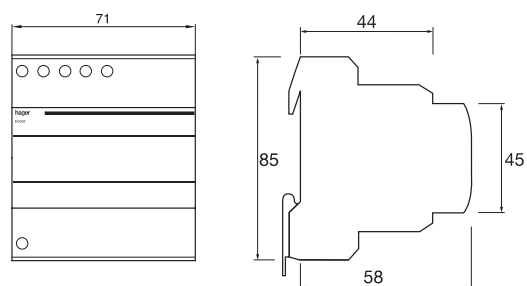

**Dimming principle**

Only one button is needed for dimming controls (increasing, decreasing) and switching on and off.  
 Quick push on button for switch on and off (principle of latching relay). Start always on last memorized level.  
 Dimming is obtained by maintaining push button. A new push on button will invert the dimming sens.

Functions	EV 011	EV 012	EV 002	EV 004	EV 100	EV 102	EV 106	EV 108	
Power indication LED			•	•	•	•	•	•	red LED switches on to indicate 230V supply
Protection against overheating	•	•	•	•	•	•			integrated electronic protection. By overheating is the available power and lighting reduced. To remedy to this phenomenon : separate dimmers with a blanking clip and/or reduce the connected load.
overheating LED			•	•	•	•			yellow LED switches lights on by overheating
protection against short-circuits	*	•	•	•	•	•			an electronic self-resetting system protects dimmers against short-circuits of load
memorization of lighting level	•	•	•	•	•	•	•	•	last dimming level is memorized last level is restored at next start
softstart function	•	•	•	•	•	•			progressive start, increases working life of lamps
output contact						•	•	•	state indicator function EV 102, or loading switch EV 106, EV 108
functioning in a system - Master (output 1/10V)						•	•	•	master products pilot other dimmers or electronic ballasts via 1/10V connection
- slave (input 1/10 V)					•	•			product piloted by 1/10V connection
ambient lighting level(scenes)				•		•		•	EV 004 1 input, EV 102 and EV 108 2 inputs
call scene with push button				•		•		•	dimming at setted speed to obtain called level
priority setting of scene by switch						•		•	dimming at setted speed to obtain called level Contact closed = priority setting. Dimmers calls previous level by opening of contact (mode 2)
spacing current	•	•	•	•	•	•	•	•	push button with LED until 5mA
dimming control on product			•	•	•	•	•	•	control by 1 or 2 push buttons according to product
<b>Setup</b>									
switching Master/Slave					•	•			EV 100, "local"stand-alone or "slave" system EV 102, "local" stand-alone, "slave" or "master" system
mini/maxi setup				•	•	•	•	•	mini/maxi setup by display, except EV100 (potentiometer mini 01 to 49 %, maxi 51 to 99 %
dimming speed						•	•	•	time needed for dimmer starting from normal state to go from 0 to 100 % by push button ; setup from 4 to 99 seconds
dimming speed at start						•	•	•	setup from 0 to 99 seconds to go from 0 to 100%
dimming speed at switch off						•	•	•	setup from 0 to 99 seconds to go from 0 to 100%
time needed to obtain a dimming level (scene)**						•		•	setup from 0 to 99 minutes and 59 seconds to go from 0 to 100%
call scene selection or priority setting scene						•		•	selection call scene (mode 1) or priority setting scene (mode 2) is available for each input
setup of dimming levels (scenes)				•		•		•	setup from 0 to 99%

\* fuse integrated

\*\* values seized in always correspond to the time needed to go from 0 to 100% : dimmer reads this signal as a slope (or speed) of constant dimming

Ex. : to go from 50% to 100% in 30 minutes ⇒ rate 60 minutes to go from 0 to 100% that is to say 30 minutes to go from 50 to 100%

### Dimmers 300W EV 011 and EV 012

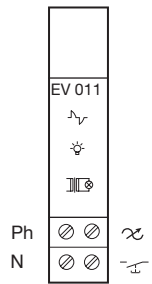

All our dimmers are compatible with pushbuttons with LED

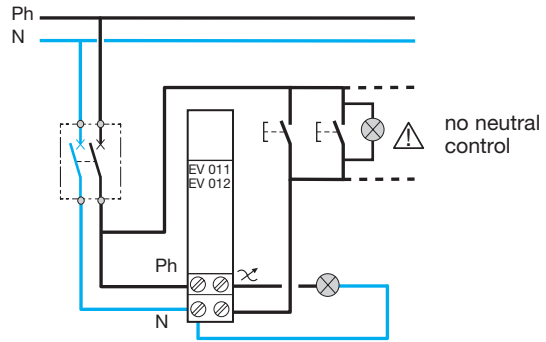

### Universal dimmer 600W EV 002

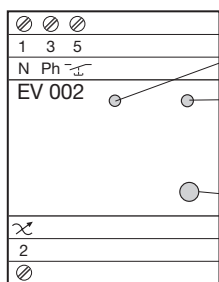

- ① 1 - default pushbutton :  
- switched on = overheating  
- blinking = overintensity
- ② 2 - LED 230 V :  
- switched on = OK 230V  
- blinking = no load connected
- ③ 3 - Lighting level switch ON/OFF adjustment

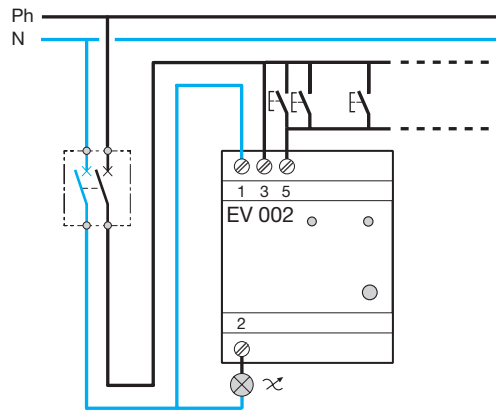

### Enhanced universal dimmer 600W EV 004

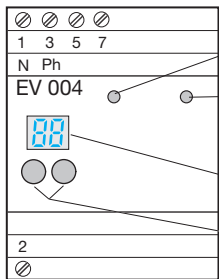

- ① 1 - default pushbutton :  
- switched on = overheating  
- blinking = overintensity
- ② 2 - LED 230 V :  
- switched ON = OK  
- blinking = no load connected  
display of lighting level in %
- ③ 3 - push buttons for :  
- dimming control
- ④ 4 - setup of lighting level - mini / maxi setup

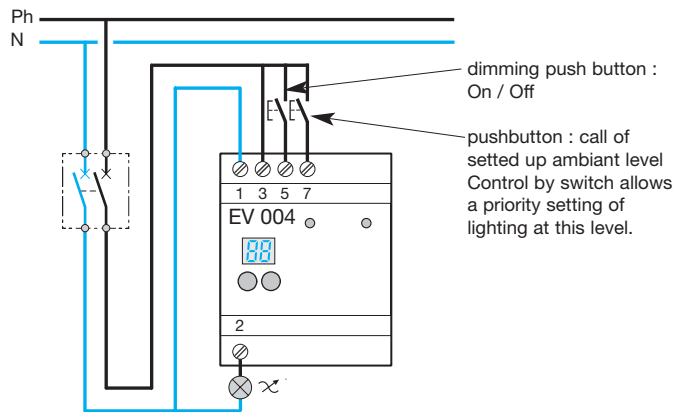

### Universal dimmer 1000 W EV 100

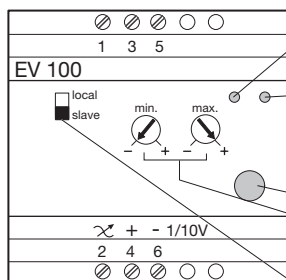

- ① 1 - default pushbutton :  
- switched on = overheating  
- blinking = overintensity
- ② 2 - LED 230 V :  
- switched ON = OK  
- blinking = no load connected
- ③ 3 - Lighting level switch ON/OFF adjustment
- ④ 4 - setup potentiometer of dimming range (mini-maxi)  
local or slave mode switch
- ⑤ 5 - local : standalone functioning  
slave : product piloted by signal of 1/10V connection

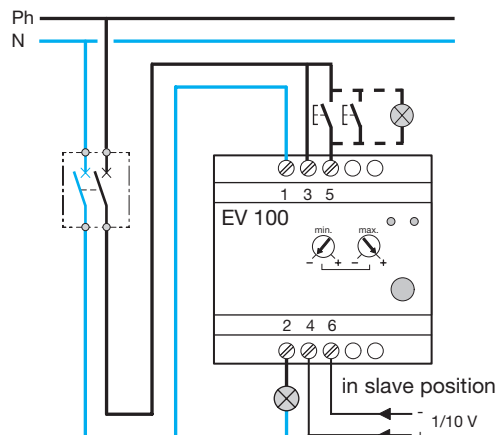

### Universal dimmer 1000 W EV 102 (with scene / input)

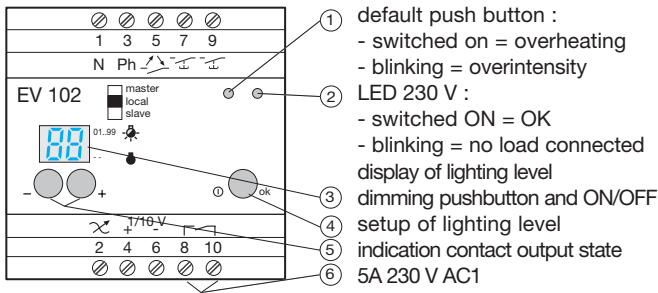

“master - local - slave” mode switch :  
 - “master” can pilot other EV 100 or EV 102 via output 1/10 V  
 - “local” stand-alone functioning of product  
 - “slave” product piloted by input signal of connection 1/10 V

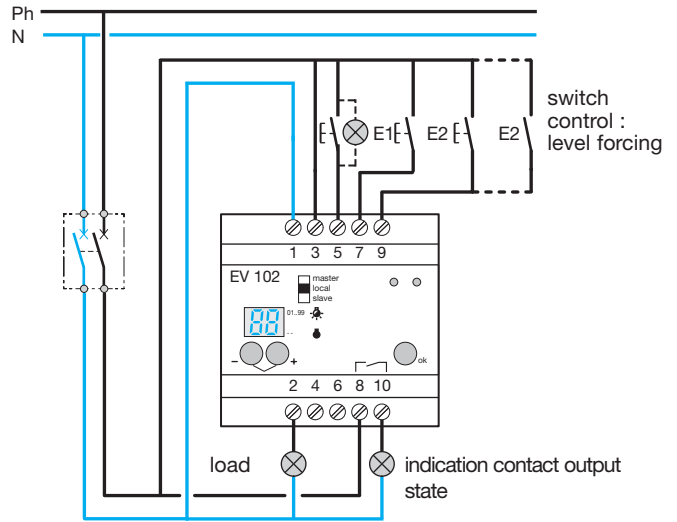

### 1/10V pilot dimmer EV 106

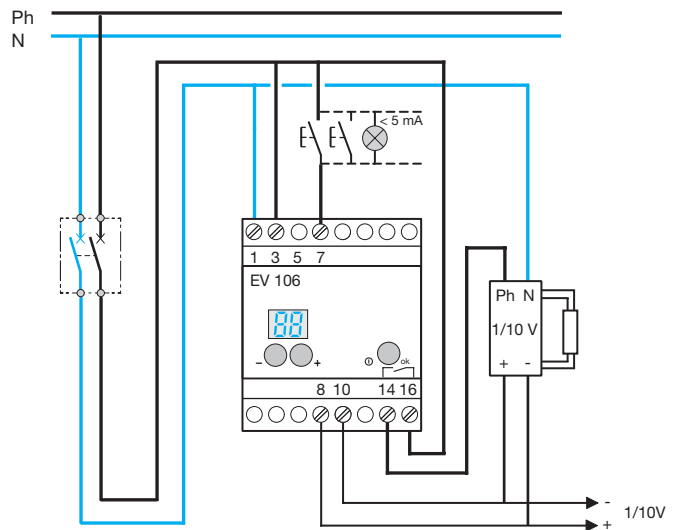
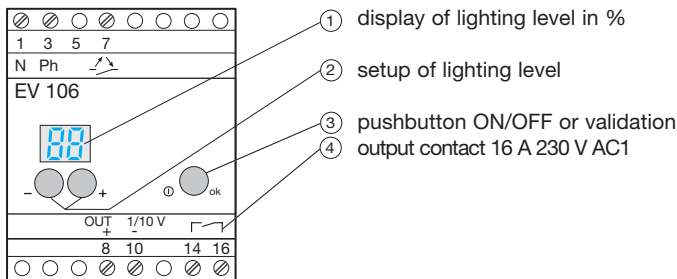

### 1/10V pilot dimmer EV 108 (with scene / input)

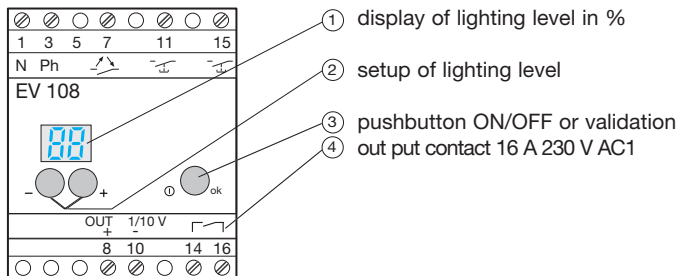

**Input E1 and E2 can call 2 ambient levels :**  
 - control by pushbutton : called level is applied out of respect for transition speed setted up  
 - control by switch : called level is applied by priority setting out of respect for transition speed setted up.  
 When 2 inputs are controled at the same time, a third level becomes available by priority setting (only by setup : mode 2 )  
 Dimming controls by pushbutton have no effect when priority setting is active.

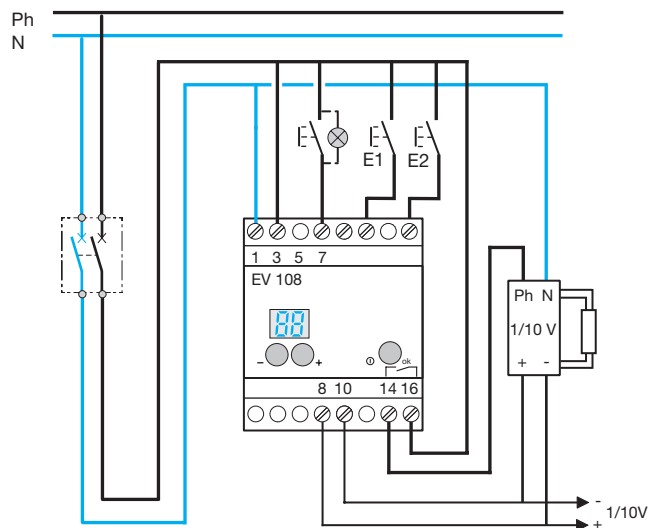

## Association of dimmer EV 102 with EV 100

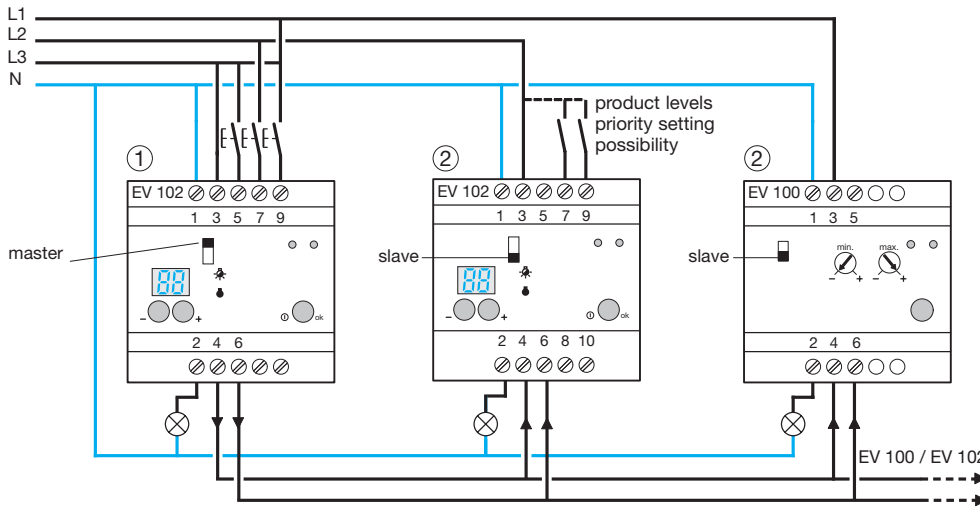

- ① mode switch in position "master" = output 1/10 V.
- ② mode switch in position "slave" = input 1/10V (in this position only priority settings with E1 and E2 are available)

**Remark :** it is possible to extract temporarily a product from system by switching from "slave" to "local".

### Use of input E1 and E2

(call of setted uplevels)  
Inputs E1 and E2 allow to call 2 or 3 setted up lighting ambiant levels. Call of levels can be done normally with pushbutton (impulse  $\leq 400$  ms) or by priority setting with switch or automation (maintained contact). Setup mode 1 or 2 allows to discriminate behaviour of dimmer by cancellation of priority setting.

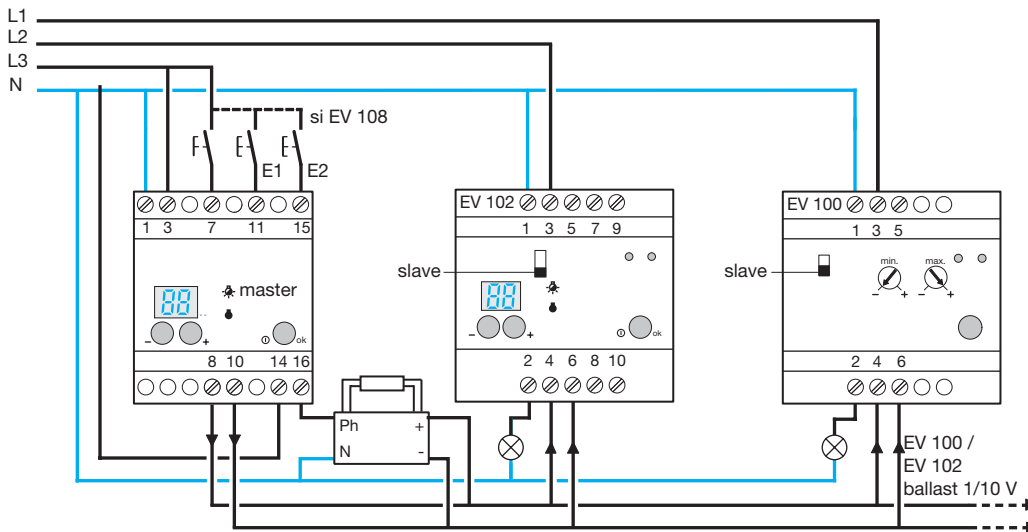

- **mode 1** (by default), corresponds to normal use.
    - Control by pushbutton, called level is applied out of respect of setted up transition. Dimmer still reacts to the other controls applied.
    - Switch control, called level is applied by priority setting out of respect of setted up transition.
- By cancellation of priority setting, lighting remains at the same level as long as no other control is given.

- **mode 2**, particularly adapted for priority setting. Same behaviour as above by call of level.
- By desactivation of priority setting, dimmer set back to the preceding state. In that mode, when the 2 entries are simultaneously active, a 3rd level becomes available in priority setting (E1+E2 = E3)

## Parameter settings for dimmers EV 102 and EV 108

parameter	functions	default value	possible value
E1	ambient level input E1	0 %	0..99 %
E2	ambient level input E2	99 %	0..99 %
E3	ambient level input E3 = E1 + E2	50 %	0..99 %
P0	dimming speed from 0 to 99 %	4"	4" ..99"
P1	mini lighting level	1 %	1 ..49%
P2	maxi lighting level	99 %	51 ..99%
P3	dimming speed at start	0"	0" ..99"
P4	dimming speed at stop	0"	0" ..99"
P5	time to reach ambient level E1	0' - 0"	0' ..99' et 59"
P6	use mode for input E1 : - 1 = call of ambient level, - 2 = priority setting	mode 1	mode 1 mode 2
P7	time to reach ambient level E2	0' - 0"	0' ..99' et 59"
P8	use mode for input E2 : - 1 = call of ambient level, - 2 = priority setting	mode 1	mode 1 mode 2
P9	time to reach ambient level E3	0' - 0"	0' ..99' et 59"

## Dimming parameters

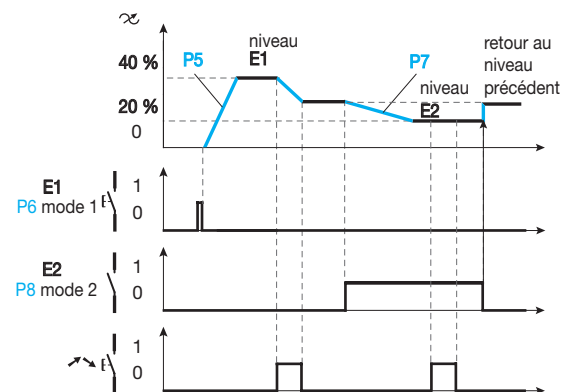
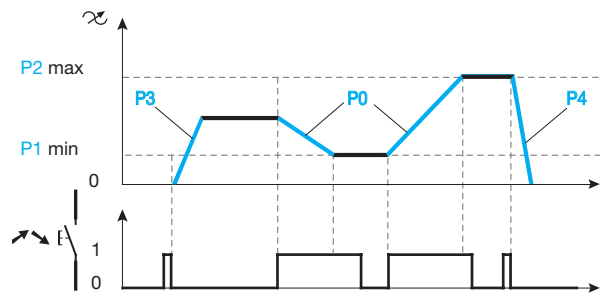

## Dimmers Main characteristics

### Technical specifications

products	EV 011	EV 012	EV 002	EV 004	EV 100	EV 102
dimming range	20 to 300 W	at 35 °C	20 to 600 W	at 45 °C	20 to 1000 W	
width	1 ■	1 ■	4 ■	4 ■	5 ■	5 ■
supply voltage	230 V ~ (+10 % -15%) 50 Hz					
power dissipation	6 W	6 W	6 W	6 W	15 W	15 W
dimming principle : - cut off at beginning of sequence (triac) - cut off at end of sequence (transistor)	triac	transistor	universal, automatic load recognition			
<b>switching capacity</b>						
230V halogen or incandescent lamps	300 W à 35 °C		600 W à 45 °C		1000 W	
VLV halogen ferromagnetic transformer	300 W at 35 °C	-	600 W at 45° C		1000 W	
VLV halogen dimming electronic transformer (Cos Ê ≥ 0,95)	-	300 W at 35 °C	600 W at 45° C		1000 W	
several circuits, total load > 1000 W fonctionning in system	-	-	-	-	EV 102 in master position + 30 EV 100 or EV 102 in slave	
1/10 V potentiometer control	-	-	-	-	yes slave position of potentiometer 100 kΩ, 200 mW logarithmic	
<b>Functional characteristics</b>						
on product (dimming function)	-	-	1 pushbutton	2 pushbutton	1 pushbutton	1 pushbutton
by local pushbutton	yes					
by luminous pushbutton	yes spacing current ≤ 5 mA					
ambient level				1 level *	-	2 levels *
levels priority settings				yes *	-	3 levels **
display of dimming level				yes 0 to 99%	-	yes 0 to 99 %
<b>Other characteristics</b>						
mini / maxi setting				mini 1 to 49% max 51 to 99%	setting via potentiomet.	mini 1 to 49 % max 51 to 99 %
output contact for state indication	no					1 contact NO 5 A ACI 230 V DC1 12V mini 0.1A
memorizing of level and softstart	yes					
protection against overheating	electronic					
protection against short-circuits	fuse	electronic				
maximum length for input pushbutton or 1/10 V connection	50 m maxi					
connection : flexible rigid	cage clamps 1 to 6□ 1.5 to 10□					
environment : storage temperature working temperature	-20 °C to +60 °C -10 °C to +35 °C		-20 °C to +60 °C -10 °C to +45 °C		-20 °C to +70 °C -10 °C to +40 °C	

(\*) Level setting from 0 to 99%. Call of level by pushbutton. Priority setting of level by maintained control (switch).

(\*\*) 3 ambient levels are available in priority setting mode :  
 - level 1 if contact E1 is closed  
 - level 2 if contact E2 is closed  
 - level 3 if contacts E1 + E2 are closed

### Requirements :

- To calculate the maximum number of lamps, it is necessary to take into account the power loss of ferromagnetic transformers (around 20%)  
The transformer should not be used at less than 75% of its nominal load.
- Electronic transformers : take into account approximatively 5% power loss.
- Respect recommandations of manufacturer of the lightings.
- **Compact fluorescent lamps with integrated ballast can not be dimmed.**
- Use a heat dissipation inserts (ref. LZ060) between remote control dimmers

**Technical specifications**

Products	EV 106	EV 108
width	4 ■	4 ■
supply voltage	230 V ~ (+10 % -15%) 50 Hz	
power dissipation	3 W	3 W
output contact	1 F 10 A 230 V ~ potential free	
load system 1/10 V liaison 1/10 V	output 1 /10 V max 50 mA (electronic ballast) or 30 dimmers EV 100 or EV 102 ; maximum cable connection 1/10 V : 50 m	
display of lighting level and setting up	yes dimming level from 0 to 99 % easy for programming and for checking all the settings	
<b>functional characteristics</b>		
on product ON / OFF - by local pushbutton - by illuminated pushbutton	3 pushbuttons 1 PB ON / OFF, 1 PB yes yes spacing current ≤ 5 mA	1 PB
wiring length	max 50 m	
ambient level (scenes) call scene by pushbutton priority setting by switch scene settings	no	2 inputs = 2 or 3 levels 2 available levels 3 levels from 0 to 99 % E1 and E2 closed = level 3
<b>dimming speed</b>		
normal dimming by pushbutton	dimming rise time from 4 to 99 seconds from level 0 to 100 %	
dimming speed at start - dimming speed at stop - speed to reach ambient level	no no no	0 to 99 seconds (duration from 0 to 100 %) 0 to 99 seconds (duration from 100 to 0 %) this parameter definises the speed used o reach the scene level (100%) : 0 to 99min. 59s
mini / maxi setup	yes, mini 1 to 49 % ; max from 51 to 99 %	
sofstart and memorization of last level	yes	
connection : flexible rigid	cage clamps 1 to 6□ 1,5 to 10□	
environment : storage temperature working temperature	-20 °C to +60 °C -10 °C to +45 °C	

\* Values seized in always correspond to the time needed to go from 0 to 100% : dimmer reads this signal as a slope (or speed) of constant dimming

Ex. : to go from 50% to 100% in 30 miutes ⇒ rate 60 minutes to go from 0 to 100% that is to say 30 minutes to go from 50 to 100%

switches ≤ 100A  
Technical characteristics

In/A	Un/V 50/60 Hz	number of poles	mechanical endurance in number of operations	electrical endurance in number of operations In-Un cos φ= 0,6	behavior with the short-circuits (en KA présumé)																		
					protection upstream																		
					fuses gL (A)						MCBs NC 10 kA (A)					MCBs MC 6 kA (A)					MCBs NM 10kA		
25	32	40	63	80	100	16	32	40	50	63	16	32	40	50	63	80	100						
25	230/400	1, 2, 3, 4	300 000	30 000	10	10					3	3				3	3						
32	230/400	1, 2, 3, 4	300 000	30 000	10	10					3	3				3	3						
40	230/400	1, 2, 3, 4	150 000	30 000			10	10					6	6	6			6	6	6			
63	230/400	1, 2, 3, 4	150 000	10 000			10	10					6	6	6			6	6	6			
80	400	2, 4	90 000	7500					10	6												6	6
100	400	2, 4	90 000	7500					10	6												6	6

free-tripping switch type SA	Im IDL alone	upstream safety device fuses				safety device upstream modular circuit breakers					safety device upstream circuit breakers MCCBs			
		14x51/22x58	22x58	22x58	22x58	NB/NC	ND	NC	NR	NM	h125 h/n	h125 h/n	h125 h/n	
		40 A gG	63 A gG	100 A gG	125 A gG	B/C	D	C	C	C				
						0,5to63A	0,5to63A	0,5to63A	0,5to63A	80to100A	25 A	≤ 63 A	≤ 125 A	
IDL II	40 A	1500 A	80 kA	32 kA	10 kA	6 kA	10 kA	10 kA	13 kA	13 kA	10 kA	8 kA	7 kA	6,5 kA
under 230 V	63 A	1500 A		32 kA	10 kA	6 kA	10 kA	10 kA	13 kA	13 kA	10 kA		7 kA	6,5 kA
	80 A	1500 A			10 kA	6 kA					10 kA			6,5 kA
IDL IV	40 A	1500 A	80 kA	32 kA	10 kA	6 kA	10 kA	10 kA	13 kA	13 kA	10 kA	8 kA	7 kA	6,5 kA
under 230/415 V	63 A	1500 A		32 kA	10 kA	6 kA	10 kA	10 kA	13 kA	13 kA	10 kA		7 kA	6,5 kA
	80 A	1500 A			10 kA	6 kA					10 kA			6,5 kA

**Safety transformers**

These transformers are designed to ensure personal safety, their primary winding are electrically separated from their secondary windings and they are intended to feed safety extra low voltage circuits  $U \leq 50V$ . A thermal overload, in the primary windings, ensures that if a short circuit or an overload occurs in the output it will not damage the device.

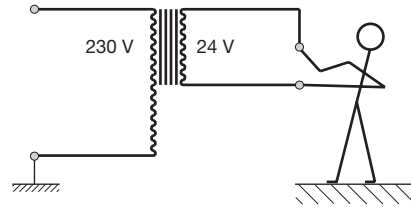

**Bell transformers**

Bell transformers are similar to safety transformers but the secondary voltages do not exceed 24 volts, they are also similarly protected against short circuits and overloads, by thermal protection in the primary winding.

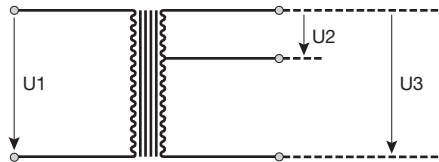

**Compliance with the standards**

The bell and safety transformers comply with EN 60742 (BS 3535).

**Technical specification**

Reference	ST 301	ST 303	ST 305	ST 312	ST 313	ST 314	ST 315
<b>Nominal power</b>	4VA	8VA	16VA	25VA	16VA	40VA	60VA
<b>Designation</b>	bell	bell	bell	safety	safety	safety	safety
<b>Primary voltage</b>	230 volts	230 volts	230 volts	230 volts	230 volts	230 volts	230 volts
<b>Secondary voltage</b>	$U_2$	12 volts $I_n = 0.33A$	8 volts $I_n = 1A$	8 volts $I_n = 2A$	12 volts $I_n = 2.08A$	12 volts $I_n = 1.33A$	12 volts $I_n = 5.25A$
	$U_3$	12 volts $I_n = 0.5A$	12 volts $I_n = 0.67A$	12 volts $I_n = 1.33A$	24 volts $I_n = 1.04A$	24 volts $I_n = 0.67A$	24 volts $I_n = 2.63A$
<b>No load</b>							
<b>Secondary voltage</b>	$U_2$	12 volts	15 volts	12.4 volts	14 volts	15.5 volts	13.6 volts
	$U_3$	18 volts	21.8 volts	18.5 volts	29 volts	29.7 volts	27 volts
<b>Galvanic insulation</b>	4kV	4kV	4kV	4kV	4kV	4kV	4kV
<b>Max functional temperature</b>	35°C	35°C	35°C	35°C	35°C	35°C	35°C
<b>Overload and S/C protection</b>	thermal cut out in the primary winding						

**number of products that can be operated simultaneously by a transformer**

transformer	reference	ST 301		ST 303		ST305		ST 312		ST 313		ST 314		ST 315	
		8V	12V	8V	12V	8V	12V	12V	24V	12V	24V	12V	24V	12V	24V
<b>power</b>		4	4	8	8	16	16	25	25	16	16	40	40	63	63
<b>bell</b>	SU 212 8/12V	1	1	3	2	5	3	-	-	-	-	-	-	-	-
<b>buzzer</b>	SU 214 8/12V	1	1	3	2	5	3	-	-	-	-	-	-	-	-
<b>relays</b>	ER 124 12V	-	-	-	-	-	-	4	-	2	-	7	-	8	-
	ER 139 12V	-	-	-	-	-	-	2	-	1	-	3	-	4	-
	ER 123 24V	-	-	-	-	-	-	-	2	-	2	-	7	-	8
	ER 138 24V	-	-	-	-	-	-	-	2	-	1	-	3	-	4
<b>contactors</b>	ES 224 24V	-	-	-	-	-	-	-	5	-	3	-	11	-	12
	ES 424 24V	-	-	-	-	-	-	-	3	-	2	-	7	-	8
<b>latching relays</b>	EP 519 12V	-	-	-	-	-	2	3	-	2	-	4	-	4	-
	EP 529 12V	-	-	-	-	-	1	2	-	1	-	3	-	3	-
	EP 513 24V	-	-	-	-	-	-	-	2	-	2	-	3	-	3
	EP 518 24V	-	-	-	-	-	-	-	2	-	2	-	3	-	3
	EP 525 24V	-	-	-	-	-	-	-	2	-	2	-	3	-	3
	EP 528 24V	-	-	-	-	-	-	-	2	-	1	-	3	-	3
	EP 541 24V	-	-	-	-	-	-	-	2	-	1	-	3	-	3

**Analogue voltmeter and ammeter**

**Technical specifications**

**Electrical characteristics**

- direct reading voltmeter : 300V and 500V for 50/60Hz
- direct reading ammeter : 5, 15, 30A
- ammeter with CT : CT/5A
- consumption : voltmeter: 1.5VA/ammeter : 0.3VA
- isolating voltage : 2kV

**Environment**

- working T°: 20°C ± 10°C class = 2
- working T°: -10°C to +50°C class > 2
- storage T°: -30°C to +75°C

**Connection capacity**

- flexible : 1 to 6□
- rigid : 1.5 to 10□

**Voltmeters range**

cat. ref.	scale	reading
<b>SM 500</b>	0-500V	direct

**Voltmeters range**

cat. ref.	scale	reading
<b>SM 005</b>	0-5A	direct
<b>SM 015</b>	0-15A	direct
<b>SM 030</b>	0-30A	direct
<b>SM 050</b>	0-50A	via CT/5A
<b>SM 100</b>	0-100A	via CT/5A
<b>SM 150</b>	0-150A	via CT/5A
<b>SM 250</b>	0-250A	via CT/5A
<b>SM 400</b>	0-400A	via CT/5A
<b>SM 600</b>	0-600A	via CT/5A
<b>SM 800</b>	0-800A	via CT/5A
<b>SM 850</b>	0-1000A	via CT/5A
<b>SM 900</b>	0-1500A	via CT/5A
<b>SM 910</b>	0-2000A	via CT/5A

**Electrical connection**

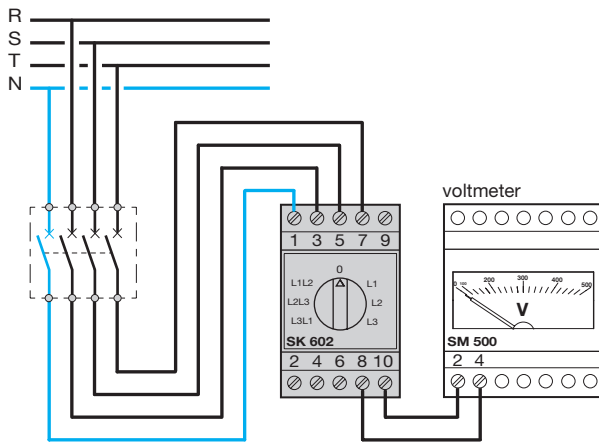

**Electrical connection**

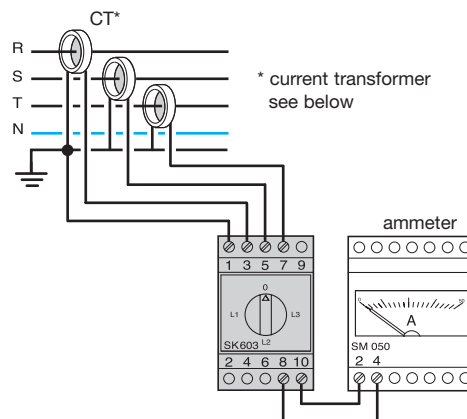

**Digital voltmeter and ammeter**

**Technical specifications**

**Electrical characteristics**

- Working voltage: 220/230V~ 50/60Hz
- Consumption: 4VA

**Environment**

- Working T°: -5 to +40°C
- Storage T°: -30°C to +75°C

**Connection**

- Connection capacity:  
flexible: 6□  
rigid: 10□

**Overload withstand of ammeters**

- 2 x In continuous
  - 10 x In for 5 seconds
- These values are to allow for starting currents

reference	product	range	Consumption	Accuracy %	reference temp. °C	accuracy variation	max permanent overload	momentary overload	frequency Hz	isolating voltage
<b>SM 501</b>	voltmeter	500 V	≤ 4,5 VA	± 1	23 ± 1°C	± 0,03% / °C	1,2 Un	2 Un/5 sec.	45 - 65	2 kV/50 Hz-1 min
<b>SM 020</b>	direct ammeter	0 - 20 A	≤ 1 VA	± 1	23 ± 1°C	± 0,03% / °C	1,2 In	10 In/5 sec.	45 - 65	2 kV/50 Hz-1 min
<b>SM 151</b> <b>SM 401</b> <b>SM 601</b> <b>SM 801</b> <b>SM 901</b> <b>SM 911</b>	ammeter with CT	0 - 150 A 0 - 400 A 0-600A 0-800A 0-1500A 0-2000A	≤ 1 VA	± 1	23 ± 1°C	± 0,03% / °C	2 In	10 In/5 sec.	45 - 65	2 kV/50 Hz-1 min
<b>SM 001</b>	Multimeter	35 to 480V~ 5 o 8000 A 40 to 80 Hz	< 0,5 VA ≤ 0,5 VA	0,5% ± digit 0,5% ± digit ± 2 Hz			1,2 In	5 In/1 sec.	40 - 80	

**Electrical connection**

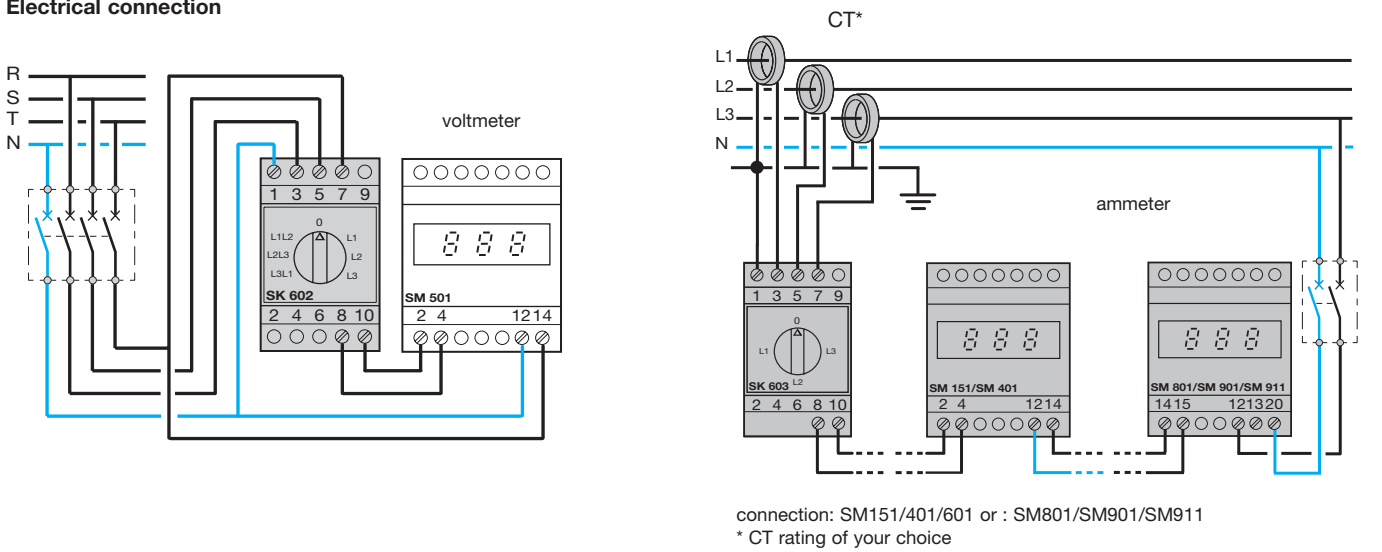

Modular devices

**Operating principle**

**For SM 501**

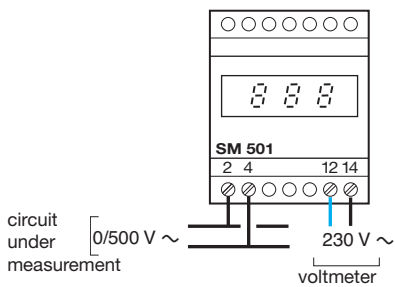

**For SM 020**

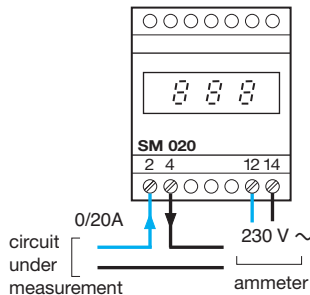

**For SM 151, SM 401, SM 601**

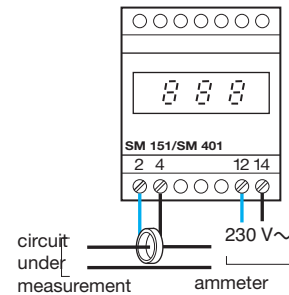

**Operating principle for SM 001**

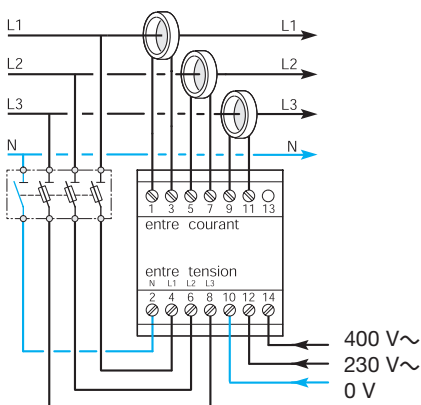

**SM 002 Door flush mounting kit for SM 001**

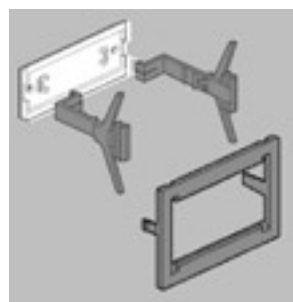

**Electrical characteristics**

- primary current: de 50 a 2000 A
- secondary current: 0 - 5 A
- frequency : 50/60 Hz
- max. permanent overload: 1.2 Un

**Connection**

- Cable flexible: 1 to 4
- Cable rigid: 1 to 6

Working temperature : from -25 to +50 °C  
Storage temperature : from -40 to +80 °C

**Current transformers**

Catalogue Reference		SR051/SR101/SR151	SR200/SR250	SR300/SR400/SR600	SR800	SR850/SR900/SR910										
for cable		Ø 21	Ø 23	Ø 35												
Busbars		20 x 5	30 x 10	40 x 10	63 x 10 or 2 x 50 x 10	80 x 10 or 2 x 63 x 10										
Ref.	A	Potential (VA)						Potential (VA)								
		Accuracy %			Accuracy %			Accuracy %			Accuracy %			Accuracy %		
		0.5	1	3	0.5	1	3	0,5	1	3	0.5	1	3	0.5	1	3
SR 051	50	-	1.25	1.5	-	-	-	-	-	-	-	-	-	-	-	-
SR 101	100	2	2.5	3.5	-	-	-	-	-	-	-	-	-	-	-	-
SR 151	150	3	4	5	-	-	-	-	-	-	-	-	-	-	-	-
SR 200	200	-	4	7	8.5	2	3	-	-	-	-	-	-	-	-	-
SR 250	250	-	6	9	11	2	3	-	-	-	-	-	-	-	-	-
SR 300	300	-	-	-	-	-	-	4	8	12	-	-	-	-	-	-
SR 400	400	-	-	-	-	-	-	8	12	15	-	-	-	-	-	-
SR 600	600	-	-	-	-	-	-	8	15	15	-	-	-	-	-	-
SR 800	800	-	-	-	-	-	-	-	-	-	6	8	10	-	-	-
SR 850	1000	-	-	-	-	-	-	-	-	-	-	-	-	10	12	15
SR 900	1500	-	-	-	-	-	-	-	-	-	-	-	-	10	12	15
SR910	2000	-	-	-	-	-	-	-	-	-	-	-	-	10	12	15

**Range of all CT's**

**SR 051, SR 101, SR 151**

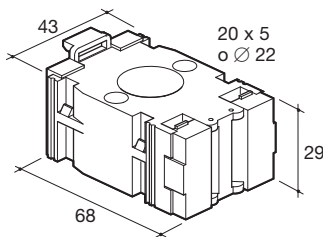

**SR 200, SR 250 for cable Ø 23 max for busbar 30 x 10 max**

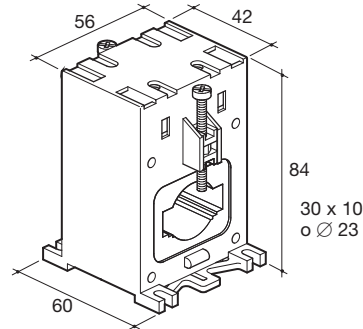

**SR 300, SR 400, SR 600 for cable Ø 35 for busbar 40 x 10 max**

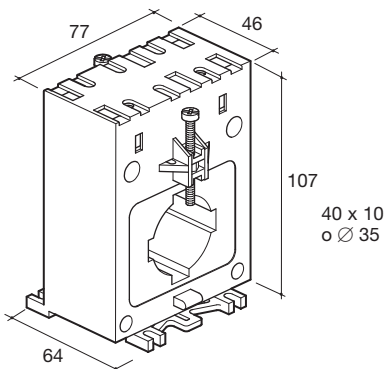

**SR 800**

max busbar 63 x 10 or 2 x 50 x 10

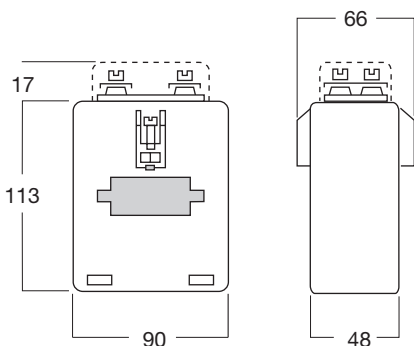

**SR 850, SR 900, SR 910**

max busbar 80 x 10 or 2 x 63 x 10

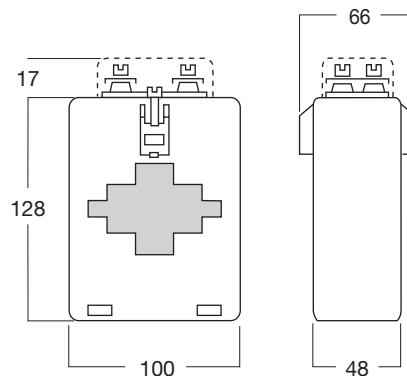

**Hours counter**

**Technical specifications**

**Electrical characteristics**

- working voltage: 230V~

**Electrical connection**

- connection in parallel on the command of the receiver (contactor coil)

**Electrical connection**

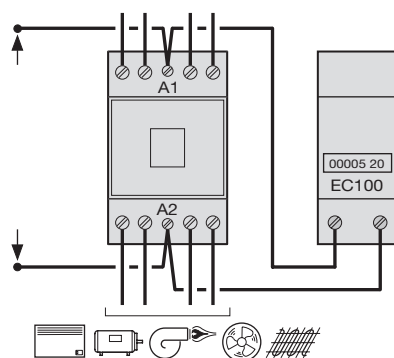

## Kilowatt hour meters 1 tariff or 2 tariffs

references	single phase direct measure						3 phase direct measure		3 phase measure via CT		
	EC 050	EC 051	EC 110	EC 111	EC 112	EC 120	EC 121	EC 310	EC 311	EC 320	EC 321
Accuracy acc IEC1036	class 1 (1%) 0,02 to 32 A ~		Class 2 (2 %) 0,32 to 32 A ~			Class 2 (2 %)		Class 2 (2 %)		Class 2 (2 %)	
I max	32 A ~ direct		32 A ~ direct			C.T. 100 / 5 A		80 A ~ direct		C.T 50 at 1500 / 5 A	
network	single phase 230 V ~ 50 Hz		single phase 230 V ~ 50 / 60 Hz			single phase 230 V ~ 50 / 60 Hz		3 phase Tri / 400 V ~ 50 / 60 Hz with or without N		3 x C.T. / 1 x C.T. 400 V ~ Tri / Tri + N 400 V ~ 2 phase	
counter	total without reset		total without reset	total + partial with reset		total + partial with reset		total + partial with reset		total + partial with reset	
display	99 999,9 digital		999 999,9 digital								
accuracy of display	0.1 kWh		0.1 kWh			0.1 kWh		0.1 kWh		0.1 kWh	
pulsed output	no	100Wh durat. 100ms	no	100 Wh duration : 15 ms		100 Wh duration : 15 ms		100 Wh duration : 60 ms		100 Wh duration : 60 ms	
tariff	simple		simple		double	simple	double	simple	double	simple	double
width	1 ■		3 ■			3 ■		7 ■		4 ■	
working T° storage T°	-10 to +45 °C -25 to +70 °C		-5 to +45 °C -20 to +70 °C			-5 to +45 °C -20 to +70 °C		-5 to +45 °C -20 to +70 °C		-5 to +45 °C -20 to +70 °C	
consumptions	1 W, 7 VA		2 W, 15 VA			2 W, 15 VA		2 W, 10 VA		2 W, 15 VA	
consum. on CT	-		-			≤ 1 VA		-		≤ 1 VA	
connection capacity	1 to 4 <sup>□</sup> flexible wire 1 to 6 <sup>□</sup> rigid wire		1 to 4 <sup>□</sup> flexible wire 1 to 6 <sup>□</sup> rigid wire			1 to 4 <sup>□</sup> flexible wire 1 to 6 <sup>□</sup> rigid wire		25 mm <sup>2</sup>		1 to 4 <sup>□</sup> flexible wire 1 to 6 <sup>□</sup> rigid wire	

**Technical particularities**

- direct reading with minimum handling
- metering of measure according to current transformer by LCD display (protected access)
- use of a single current transformer for 3 phases network
- connection of current transformer is not dependant of polarity
- tolerance in voltage supply till ± 20 %

**Pulsed output**

- 1 pulse per 100 Wh (output relay)
- simple galvanic insulation 2 kV
- Umax = 100 Vdc I<sub>max</sub> = 0.3 Adc
- Number of handlings = 10<sup>8</sup> (10 Vdc 10 mA)

**Recommendations**

- leave a space of 0.5 ■ on each side of a direct connection meter
- C.T. are not polarized
- meters don't work on network 3 phase 230V between phase, but only on network 3 phase 400V between phase with or without neutral

**Recommendations for connection of secondary circuit for one or several CT**

- no common point for connection on meter
- never connect to earth

**Connection diagram  
EC 050, EC 051**

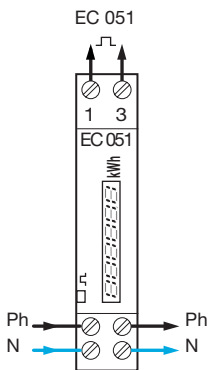

**Single phase connection diagram  
EC 120 and EC 121**

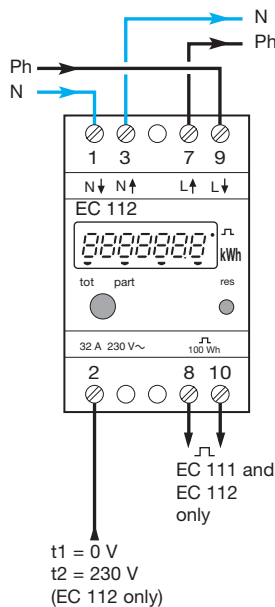

**EC 120 and EC 121**

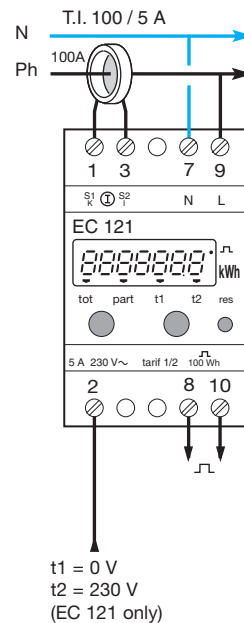

	<b>Three phase CT operated</b>
<b>References</b>	EC 320   EC 321
<b>Accuracy acc. IEC1036</b>	class 2
<b>Input</b>	CT 50 to 1500/5A
<b>I<sub>max</sub></b>	6A
<b>I<sub>b</sub></b>	5A
<b>I<sub>starting</sub></b>	0.06A
<b>Voltage</b>	three phase
	230 - 400V AC (±20%) L1&L2 50/60Hz (±2Hz) IP30 (under cover) IK02
<b>Network</b>	3 phase + N with 3 CT or 1 CT 3 phase with 3 CT 2 phase (R&Y) with 2 CT
<b>Width in I 17.5mm</b>	4
<b>Counter</b>	total + partial with reset
<b>Display</b>	999 999,9 digital
<b>Unit display</b>	0.1kWh
<b>Pulsed output</b>	100 Wh
<b>Pulse duration</b>	60ms+/-3ms
<b>External supply</b>	100 Vdc max
<b>Operating current</b>	0.3 Adc max
<b>Insulate level</b>	2kV
<b>Cycle on load</b>	10puis8 (10Vdc 10mA)
<b>Current input Consumption</b>	<1VA for phase to I <sub>max</sub>
<b>Tariff</b>	single double
<b>Working temp.</b>	-5°C to +45°C
<b>Storage temp.</b>	-20°C to +70°C
<b>Humidity (without condensation)</b>	85%
<b>Consumption</b>	2W, 3VA
<b>Connection capacity</b>	flexible : 1 to 6□ rigid : 1.5 to 10□

**Technical specificities**

- direct reading with a minimum of handling
- measuring calibration according to the CT is made by display on the LCD screen (protected access)
- use of only one CT in balanced three phase network
- connection of the CT independent from his polarity
- indifferent to voltage fluctuation up to ±20%

**Installation recommendations**

- it is recommended to foresee a space of 0.5 I on each side of a meter with direct connection

**Recommendations to connect the secondary circuit of one or more CT's**

- no common point for connection on the meter
- never connect to earth

**Electrical connection**

**There are 2 solutions to connect the three phases and the neutral to the kWh meter :**

1. Pass the cables through the kWh meter, without cutting and stripping them.
  - position the terminal covers by turning through 180°
  - pass the cables through the kWh meter
  - tighten the upper and the bottom terminals to clamp the cable in position
  - tighten at the maximum the piercing screw to allow the voltage measurement.
  - the cables must have a cross section of
    - 10□ minimum
    - 25□ max. this means an external diameter of 10,5 mm maximum.

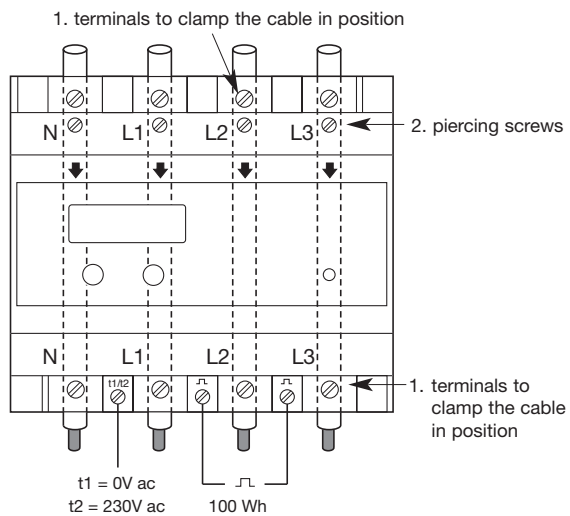

2. It is also possible to connect stripped cables.
  - connect your incoming and outgoing cables cut and stripped.
  - position the terminal covers by turning through 180°
  - make all necessary connections
  - the cables must have a cross section of
    - 4□ minimum
    - 50□ max. this means a diameter of 10,5 mm maximum (bared).

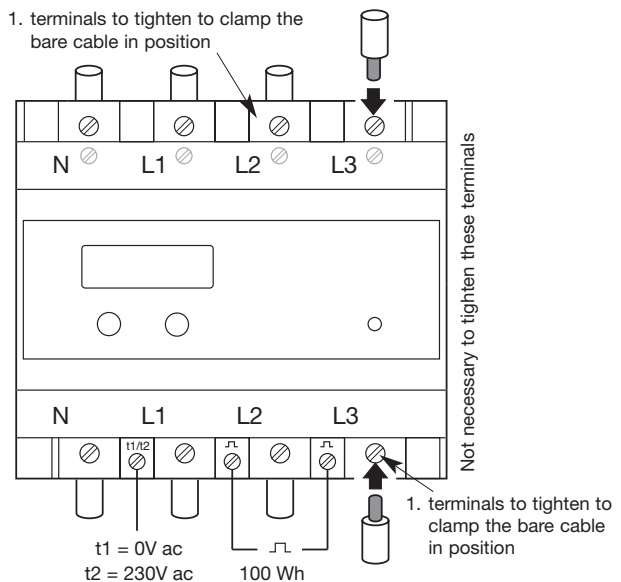

# Kilowatt hour meters 1 tariff or 2 tariffs

**Metering for equilibrated 3 phase network with neutral 230/400 V~**

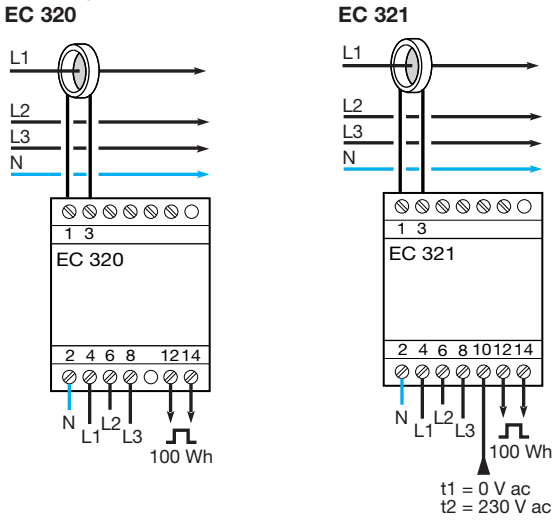

**Metering for unbalanced voltage 3 phase network with neutral 230/400 V~**

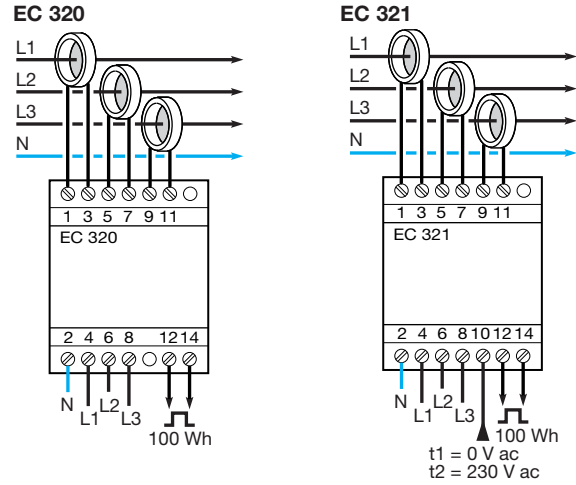

**Metering for unbalanced voltage 3 phase network without neutral 230/400 V~**

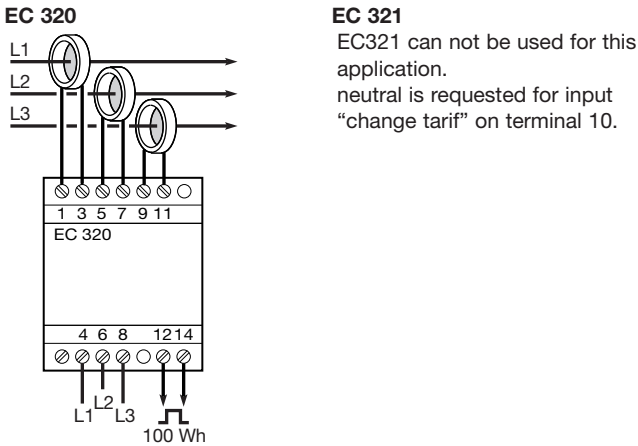

**Metering for 2 phase network 400 V~**

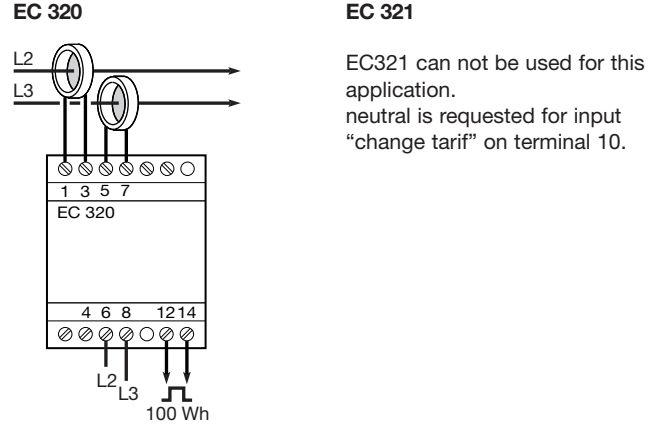

**Metering for 3 phase network associated with a ammeter and its phase switch 230/400 V ~**

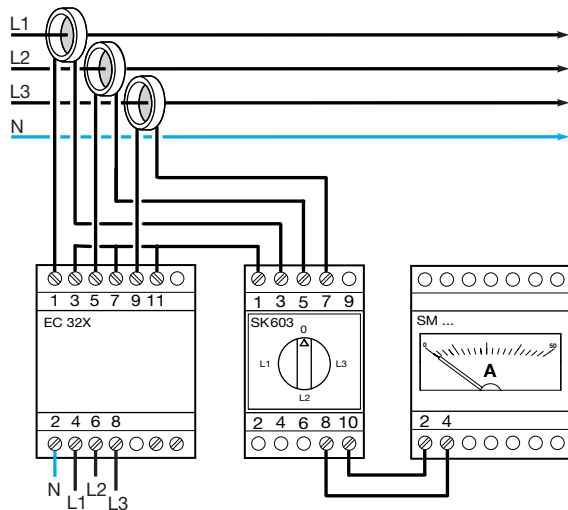

**3 phase connection diagram EC 310 / EC 311**

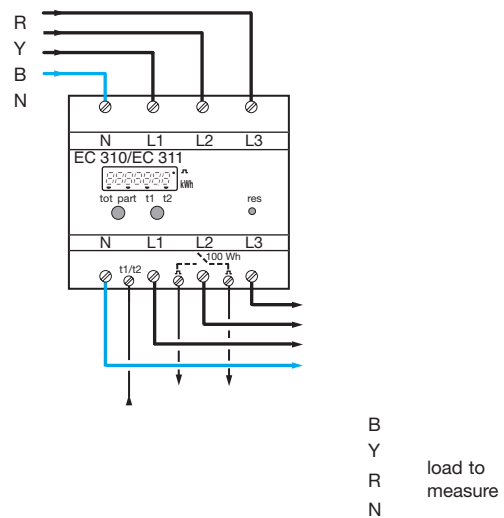

**Notice :** These meters are not suitable for a three phase voltage 110/230V~ (with or without neutral).

t1 = 0V pulsed  
t2 = 230V output  
(EC 311 only)

References	EU 100	EU 101	EU 301	EU 302	EU 300	EU 102	EU 103
Function	single phase compressor control relay	single phase compressor control relay	three phase compressor control relay	three phase voltage control relay	phase control relay	voltage control relay with LCD	current control relay with LCD
LCD indicator	No					measured voltage	measured current
Power supply	230 V AC +10% -15% 50/60Hz +/-2%		230 V AC +10% -15% 50/60Hz +/-2%		230 V AC +10% -15% 50/60Hz +/-2%		
Power consumption	< 5 VA						
Output contact	8A - AC1 - 250V closed : normal status opened : default status						
Disconnection time	5min / 10min			-			
Response time	200 ms			0,1..12s set via potentiometer		200 ms	
Monitoring function	Monitoring function over/under voltage				Monitor. funct. under voltage loss of phase	over voltage over current under voltage band	under current band
Monitoring levels	Umin : 0.75Un Umax : 1.2Un	Umin/Umax : +/-5% to +/-20%Un set via potentiometer		Umin : +/-5 to +/-20% Un Umax : 1.15Un	Asymmetry +/-5% to +/-20% Umin : 0.70Un	DC : 15V to 700V AC : 15V rms to 480V rms	DC : 0.1 to 10A AC : direct : 0.1to10A or via current transformer : X/5
Hysteresis						5 to 50%	
Latching function	No			Yes		No	
Supervised voltage	the power supply						
Width	2 modules					2 modules	
LED power supply : green	lights when powered						
LED default information : red	lights in case of fault, flashing during time elapses, off during normal status						
LED asymmetry information : yellow					asymetry fault		
Ik	3						
ingress protection	IP 20						
Working temperature	-20 to +55°C						
Storage temperature	-40 to +70°C						
Connexion flexible	0.75 to 4mm <sup>2</sup>						
rigid	1 to 6 mm <sup>2</sup>						

Modular devices

**Air conditioning control relay single phase EU 100**

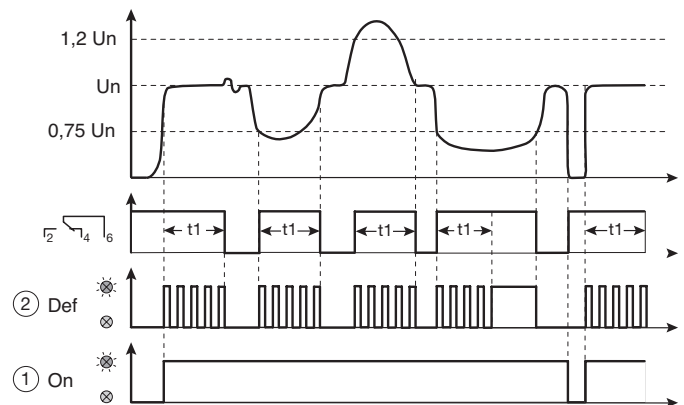
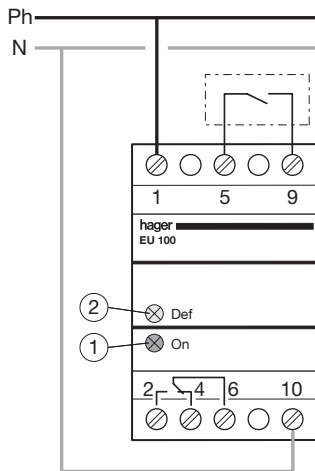

Voltage control relay single phase EU 102

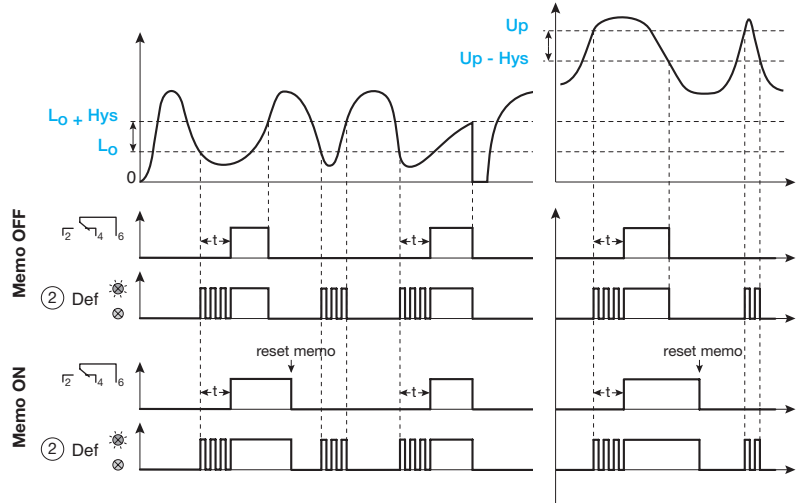
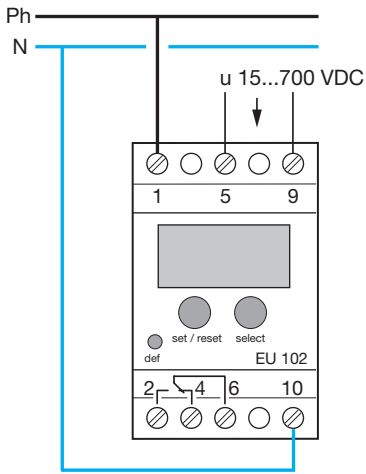

Current control relay single phase EU 103

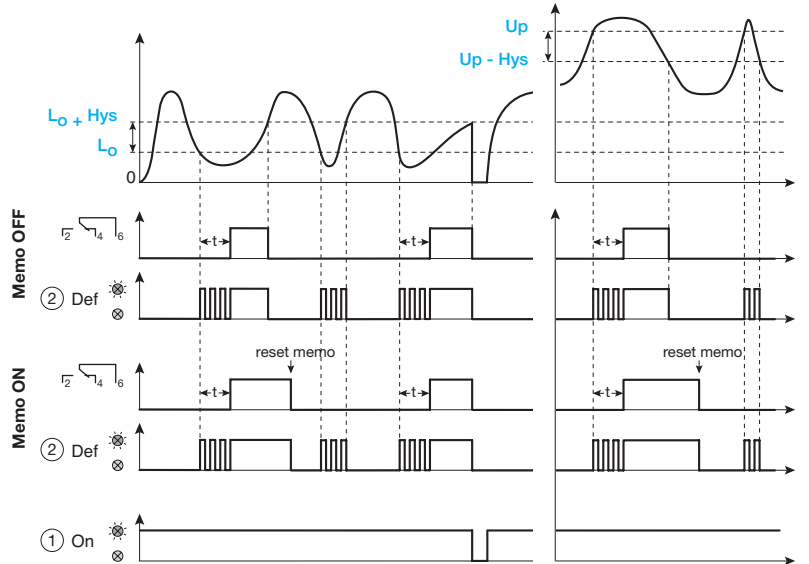
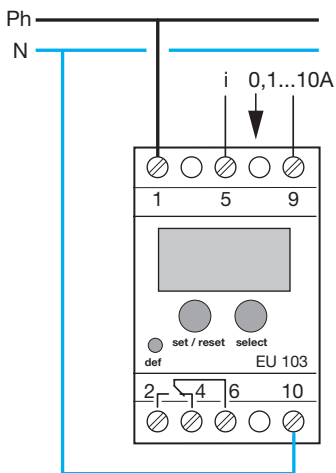

Phase control relay EU 300

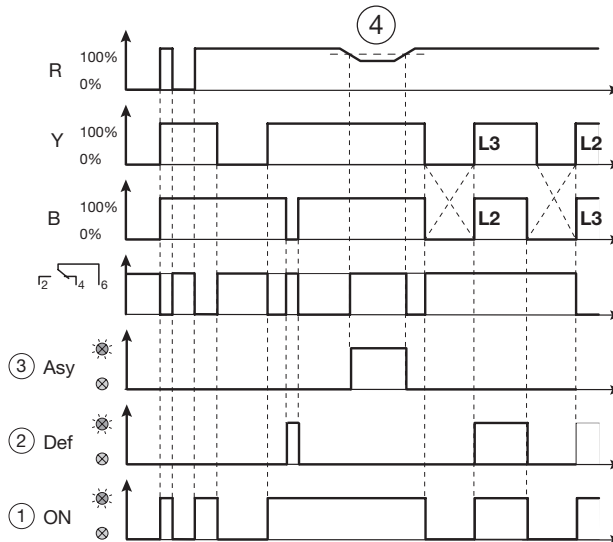
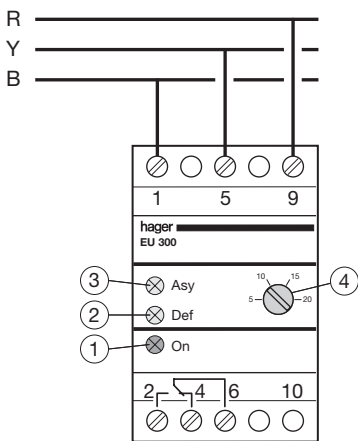

Air conditioning control relay single phase EU 101

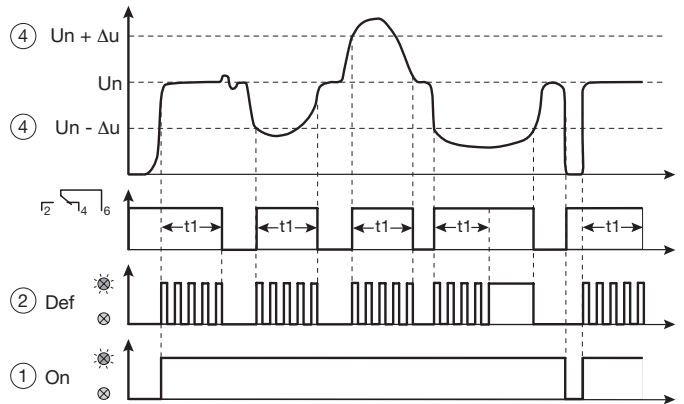
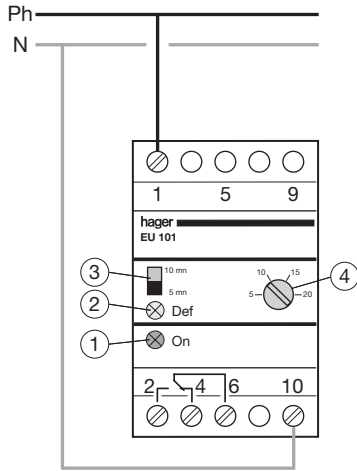

Modular devices

Air conditioning control relay three phase EU 301

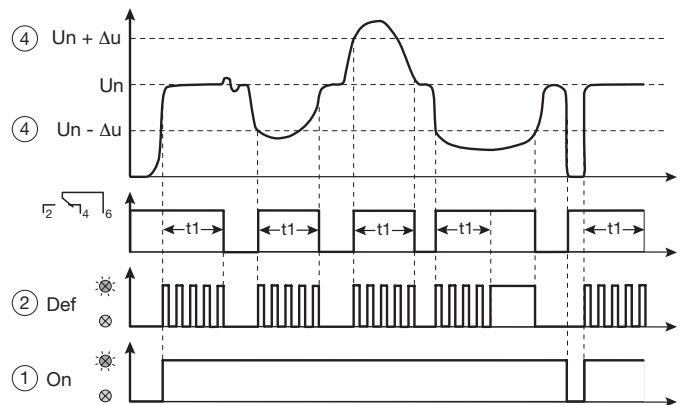
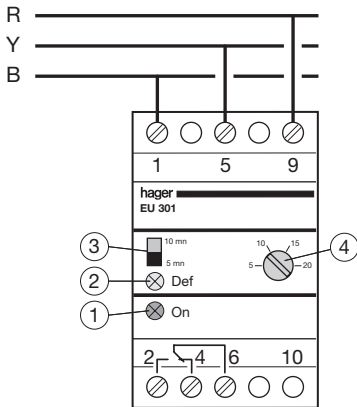

Voltage control relay three phase EU 302

